



**Technický a zkušební ústav  
stavební Praha, s.p.**  
Prosecká 811/76a  
190 00 Prague  
Czech Republic  
T: +420 286 019 400  
W: www.tzus.cz



## European Technical Assessment

**ETA 14/0425**  
of 28/04/2020

### General Part

**Technical Assessment Body issuing the European Technical Assessment**  
Technický a zkušební ústav stavební Praha, s.p.

<b>Trade name of the construction product</b>	DMX®
<b>Product family to which the construction product belongs</b>	Product area: 13 Three-Dimensional Nailing Plates
<b>Manufacturer</b>	DOMAX Sp.z o.o. Aleja Parku Krajobrazowego 109 84-207 Koleczkowo Łężyce Republic of Poland
<b>Manufacturing plant</b>	DOMAX Sp.z o.o. Aleja Parku Krajobrazowego 109 84-207 Koleczkowo Łężyce Republic of Poland
<b>This European Technical Assessment contains</b>	65 pages including 6 annexes, which form an integral part of this European Technical Assessment
<b>This European Technical Assessment is issued in accordance with Regulation (EU) No 305/2011, on the basis of</b>	ETAG 015 used as European Assessment Document (EAD)
<b>This version replaces</b>	ETA 14/0425, version 01, issued on 13/11/2014

Translations of this European Technical Assessment in other languages shall fully correspond to the original issued document and should be identified as such.

Communication of this European Technical Assessment, including transmission by electronic means, shall be in full (excepted the confidential Annex(es) referred to above). However, partial reproduction may be made, with the written consent of the issuing Technical Assessment Body - Technical and Test Institute for Construction Prague. Any partial reproduction has to be identified as such.

## 1 Technical description of the product

The three-dimensional nailing plates DMX<sup>®</sup> are one-piece, non-welded or welded (KKB, PS, SDP 90 A, SDP 90 B, SDP 100 A, SDP 100 B, SDP 120 A, SDP 120 B, SDSP 70 A, SDSP 70 B) elements, made of the cold-formed steel sheet grade DX51D according to EN 10346 with the zinc coating mass of 275 g/m<sup>2</sup>, electrogalvanized steel DC01 according to EN 10131 with corrosion protection Fe/Zn 12 or S235 according to EN 10025-2 with minimum 12 μm of zinc layer. Elements SD and SDS have extra powder coating 60 μm (see list below). The three-dimensional nailing plates DMX<sup>®</sup> correspond to the drawings and dimensions given in Annex 1.

Technical description of the product

Type of Domax connector	Made of	Kind of corrosion protection
KLR	DX51D	Z275
KP	DX51D	Z275
KPK	DX51D	Z275
KPL	DX51D	Z275
KR	KR 1 – DC01	Fe/Zn 12
	KR 2 – DX51D	Z275
	KR 3 – DX51D	Z275
KRD	DX51D	Z275
LU	DX51D	Z275
WBC	DX51D	Z275
WBU	DX51D	Z275
łB	S235	Fe/Zn 12
NT	DX51D	Z275
KKB	S235	Fe/Zn 12
PS	S235 / B500	Fe/Zn 12
KPS	DX51D	Z275
SD	SDLZ 1 – DX51D	Z275 + Powder Coating 60 μm
	SDKLR 1 – DX51D	Z275 + Powder Coating 60 μm
	SDKL 1 – DX51D	Z275 + Powder Coating 60 μm
	SDP 90 A – S235	Fe/Zn 12 + Powder Coating 60 μm
	SDP 90 B – S235	Fe/Zn 12 + Powder Coating 60 μm
	SDP 100 A – S235	Fe/Zn 12 + Powder Coating 60 μm
	SDP 100 B – S235	Fe/Zn 12 + Powder Coating 60 μm
	SDP 120 A – S235	Fe/Zn 12 + Powder Coating 60 μm
	SDP 120 B – S235	Fe/Zn 12 + Powder Coating 60 μm
	SDD 85 A – DX51D	Z275 + Powder Coating 60 μm
	SDD 85 B – DX51D	Z275 + Powder Coating 60 μm
SDS	SDSP 70 A – S235	Fe/Zn 12 + Powder Coating 60 μm
	SDSP 70 B – S235	Fe/Zn 12 + Powder Coating 60 μm
	SDSKW 2 – DX51D	Z275 + Powder Coating 60 μm
	SDSKW 8 – DX51D	Z275 + Powder Coating 60 μm
	SDSKP 1 – DX51D	Z275 + Powder Coating 60 μm
	SDSKP 5 – DX51D	Z275 + Powder Coating 60 μm
	SDSKM 7 – DX51D	Z275 + Powder Coating 60 μm
	SDSWBZ 10 – DX51D	Z275 + Powder Coating 60 μm
	SDSWBZ 11 – DX51D	Z275 + Powder Coating 60 μm
	SDSWBZ 14 – DX51D	Z275 + Powder Coating 60 μm
	SDSWBZ 21 – DX51D	Z275 + Powder Coating 60 μm
	SDSWBZ 26 – DX51D	Z275 + Powder Coating 60 μm
	SDSWBZ 30 – DX51D	Z275 + Powder Coating 60 μm

## 1.1 Identification

The identification parameters and reference to product specifications for identifying the materials and components which constitute the three dimensional nailing plates are given in Annex 1.

## 2 Specification of the intended use(s) in accordance with the applicable European Assessment Document (hereinafter EAD)

The DMX® three-dimensional nailing plates are intended to be used in timber to timber connections as well as connections between a timber joist and a concrete structure or a steel member. For connecting the mutually perpendicular, load-bearing, solid timber elements, in side-grain to side-grain configurations, in joints for which requirements for mechanical resistance and stability in the sense of the basic requirement 1 of Regulation (EU) No 305/2011 shall be fulfilled.

Ring shank nails according to EN 14592 with the diameter of 4 mm and characteristic tensile capacity  $F_{ax,Rk}$  not less than 1.80 kN shall be used for connections made with the DMX® three-dimensional nailing plates.

In respect of the requirements concerning corrosion resistance, DMX® three-dimensional nailing plates are for use in timber structures subjected to the internal conditions defined by service classes 1, 2 and 3 (connectors with additional powder coating) according to EN 1995-1-1 (Eurocode 5), in corrosion aggressiveness categories C1 and C2 according to EN ISO 12944-2, without action of acid gases or vapours.

The provisions made in this European Technical Approval are based on an assumed working life of the product of 50 years. The indications given on the working life cannot be interpreted as a guarantee given by the producer or approval body, but are to be regarded only as a means for choosing the right products in relation to the expected economically reasonable working life of the works.

The assessment of the fitness of the DMX® three-dimensional nailing plates for the intended use has been made in compliance with the ETAG 015 “*Three-dimensional nailing plates*” used as European Assessment Document (EAD).

### 2.1 Installation of three-dimensional nailing plates

The fitness for use of the DMX® three-dimensional nailing plates can only be assumed if the following conditions of installation are met:

- installation is carried out by appropriately qualified personnel under the supervision of the person qualified for this work,
- the original three-dimensional nailing plates only are used, supplied by the manufacturer together with the appropriate ring shank nails defined in clause 2.2.2,
- three-dimensional nailing plates installation is in accordance with the manufacturer's installation guide,
- before placing the three-dimensional nailing plates, the characteristics of timber members (type, class and moisture content) in which the nailing plates are to be placed are checked to ensure that they are identical or better than the characteristics of timber members used in testing in which the characteristic load-carrying capacities were determined,
- timber member placed in three-dimensional nailing plate does not contain the waness and the gap between the connected elements does not exceed 3 mm.

### 3 Performance of the product and references to the methods used for its assessment

The assessment of the fitness for use of the three dimensional nailing plates according to the basic work requirements (BWR) were carried out in compliance with ETAG 015.

The European Technical Assessment is issued for the three dimensional nailing plates on the basis of agreed data and information, deposited at Technický a zkušební ústav stavební Praha, s.p., which identifies three dimensional nailing plates that has been assessed and judged. Changes to the plates or production process which could result in this deposited data and information being incorrect should be notified to Technický a zkušební ústav stavební Praha, s.p. before the changes are introduced. Technický a zkušební ústav stavební Praha, s.p. will decide whether or not such changes affect the ETA and consequently the validity of the CE marking on the basis of the ETA and if so whether further assessment or alternations to the ETA shall be necessary.

**Table 1** Essential characteristics of the product

	Essential characteristic	Performance
3.1 BWR 1: Mechanical resistance and stability		
3.1.1	Joint strength	See Annex 3
3.1.2	Joint stiffness	NPA
3.1.3	Joint ductility in cyclic testing	NPA
3.2 BWR 2: Safety in case of fire		
3.2.1	Reaction to fire	The steel elements are classified as class A1 of reaction to fire (non-combustible products) in accordance with EN 13501-1+A1 and to European Commission Decision 96/603/EC amended by European Commission Decision 2000/605/EC.
3.2.2	Resistance to fire	NPA
3.3 BWR 3: Hygiene, health and the environment		
3.3.1	Content, emission and/or release of dangerous substances	See 3.3.1
BWR 4: Safety and accessibility in use		
Not relevant		
BWR 5: Protection against noise		
Not relevant		
BWR 6: Energy economy and heat retention		
Not relevant		
BWR 7: Sustainable use of natural resources		
Not relevant		

#### 3.1 Mechanical resistance and stability (BWR 1)

##### 3.1.1 Joint strength

The characteristic load-carrying capacities of joints loaded according to static diagrams (shown in Annex 2), determined by tests carried out according to ETAG 015, clause 5.1.3, are given in Annex 3. The characteristic load-carrying capacities of joints for other load direction shall be calculated on the basis of EN 1995-1-1 (Eurocode 5) or according to national regulations. The design values shall be determined according to EN 1995-1-1 (Eurocode 5).

Following the requirements of ETAG 015 for the minimum number of specimens for determining the characteristic load-bearing capacities through testing the applicant provided the laboratory with 5 specimens of each test assembly distinguished by a connector type, configuration of the connection and static scheme (direction of force actions).

The modifications of standard procedures applied come from the requirements of ETAG 015. The procedure specified in standard ref. 6 is modified as required in EOTA TR 016 *Method of testing Three-Dimensional Nailing Plates* with examples, namely the procedure corresponding to the case “*Test specimens fulfil EN ISO 8970*”, which as stated above was relevant in all cases.

As agreed in between the applicant and the laboratory the manufacture, conditioning and transportation of the test assemblies into the laboratory was carried out by the applicant under specified conditions.

The conditions were as follows:

The timber members used – sawn timber blanks of European whitewood, grade C24, free from major defects in the area of the connector. Selection of timber members within a test group (the five specimens) referring to densities should comply with the requirements of EN ISO 8970. During testing of connectors at Technický a zkušební ústav stavební Praha, s.p. were used a timber specimens with characteristic density  $350 \text{ kg/m}^3$ .

The samples came in four successive deliveries in condition “fit for direct testing” meaning that conditioning the timber elements to equilibrium moisture content in line with the requirements of Cl. 2.4.1.1.3.3. ETAG 015 was carried out by the applicant. The completed and conditioned test assemblies were delivered protected by a plastic wrap.

Conditioning in the laboratory consisted in equalisation of temperatures of the specimens and the ambient temperature by storing in the laboratory for 3 days as a minimum, during which time the specimens remained wrapped in plastic cover. In the majority of cases the term of storing was much longer.

Dimensions of the timber members, relative moisture content and weight of the assemblies were determined for control whether the density of timber blanks complies with the requirements of EN ISO 8970. This was carried out with specimens unwrapped just before the load testing of each specimen. It is stated that in the majority of cases the requirement of the standard have been met. In several cases when the mean wood density was above the scope stated by the standard, allowance was made in line with the respective provision of EOTA TR 016.

### **3.1.2 Joint stiffness**

No performance assessed.

### **3.1.3 Joint ductility in cyclic testing**

No performance assessed.

## **3.2 Safety in case of fire (BWR 2)**

### **3.2.1 Reaction to fire**

The steel elements are classified as class A1 of reaction to fire (non-combustible products) in accordance with EN 13501-1+A1 and to European Commission Decision 96/603/EC amended by European Commission Decision 2000/605/EC.

### **3.2.2 Resistance to fire**

Performance in relation to fire resistance would be determined for the complete structural element with any associated finishes, therefore there is no performance assessed option used to this Basic Work Requirement.

### **3.3 Hygiene, health and the environment (BWR 3)**

#### **3.3.1 Content, emission and/or release of dangerous substances**

The manufacturer submit a written declaration whether or not and in which concentrations the three dimensional nailing plates contain substances which are classified as dangerous according to Directive 67/548/EEC and European Commission Regulation No 1272/2008.

In addition to the specific clauses relating to dangerous substances, there may be other requirements applicable to the products falling within their scope (e.g. transposed European legislation and national laws, regulations and administrative provisions). In order to meet the provisions of the Construction Products Regulation, these requirements need also to be complied with, when and where they apply.

#### **3.4 Safety and accessibility in use (BWR 4)**

Not relevant.

#### **3.5 Protection against noise (BWR 5)**

Not relevant.

#### **3.6 Energy economy and heat retention (BWR 6)**

Not relevant.

#### **3.7 Sustainable use of natural resources (BWR 7)**

For the sustainable use of natural resources no performance was assessed for this product.

### **3.8 Aspects of durability, serviceability and identification**

#### **3.8.1 Durability and serviceability**

The DMX<sup>®</sup> three-dimensional nailing plates have been assessed as having satisfactory durability and serviceability when used in conditions defined by service classes 1 and 2 according to EN 1995-1-1 (Eurocode 5).

#### **3.8.2 Identification**

Each three-dimensional nailing plate is to be marked with the symbol and the product type designation according to the Annex 1.



#### 4 Assessment and verification of constancy of performance (hereinafter AVCP) system applied, with reference to its legal base

According to the decision 1997/638/EC<sup>1</sup>, of the European Commission the system(s) of assessment and verification of constancy of performance (see Annex V to Regulation (EU) No 305/2011 and Commission delegated Regulation (EU) No 568/2014) given in the following table applies:

Product(s)	Intended use(s)	Level(s) or class(es)	Attestation of conformity system(s)
<b>Shear plates, toothed-plate connectors, punched nail plates, nailing plates</b>	For structural timber products		2+

#### 5 Technical details necessary for the implementation of the AVCP system, as provided for in the applicable EAD

Issued in Prague on 28.04.2020

By  
Mária Schaan  
Head of the TAB

#### Annexes:

- Annex 1 Product details and definitions
- Annex 2 Loading and calculations according to static diagrams
- Annex 3 The characteristic load carrying capacities of connectors
- Annex 4 Nailing patterns
- Annex 5 Specification of connection elements
- Annex 6 Reference documents

---

<sup>1</sup> Official Journal of the European Communities L 268/36 of 19.9.1997

# ANNEX 1

## PRODUCT DETAILS AND DEFINITIONS

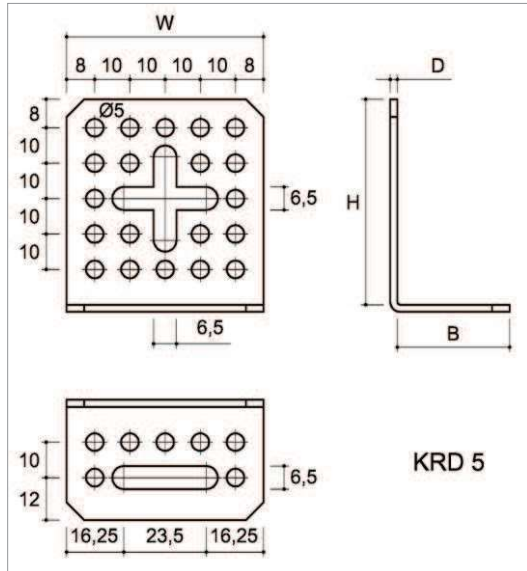


Figure 1 Type KRD 5

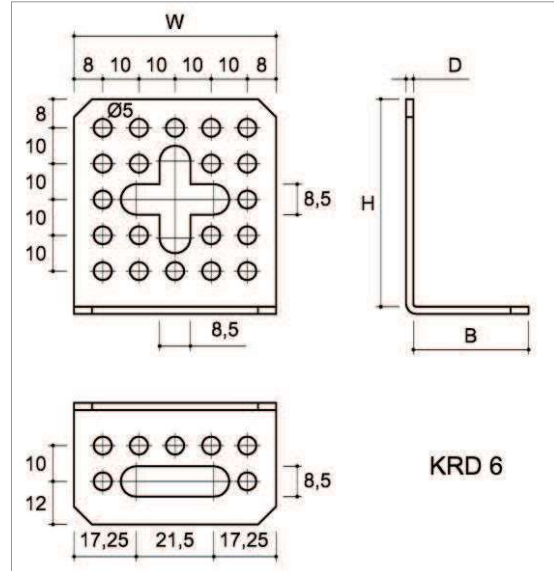
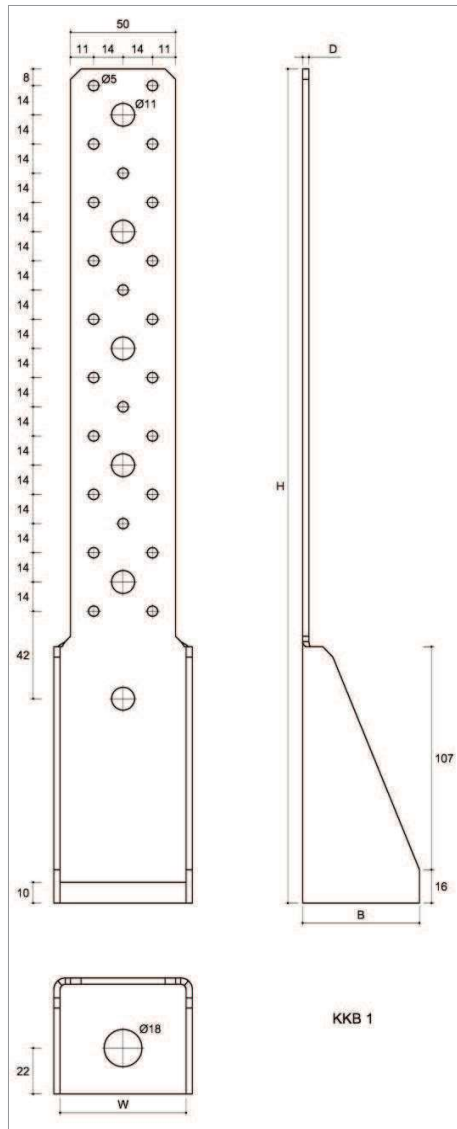


Figure 2 Type KRD 6

Table 2 KRD three-dimensional nailing plate symbols and dimensions

Symbol	Dimensions, mm				Number of holes
	W	H	B	D	
KRD 5	56	58	32	2	27
KRD 6	56	58	32	2	27





**Figure 3** Type KKB 1

**Table 3** KKB three-dimensional nailing plate symbols and dimensions

Symbol	Dimensions, mm				Quantity of openings		
	W	H	B	D	∅ 5	∅ 11	∅ 18
KKB 1	60	400	56	3	24	6	1

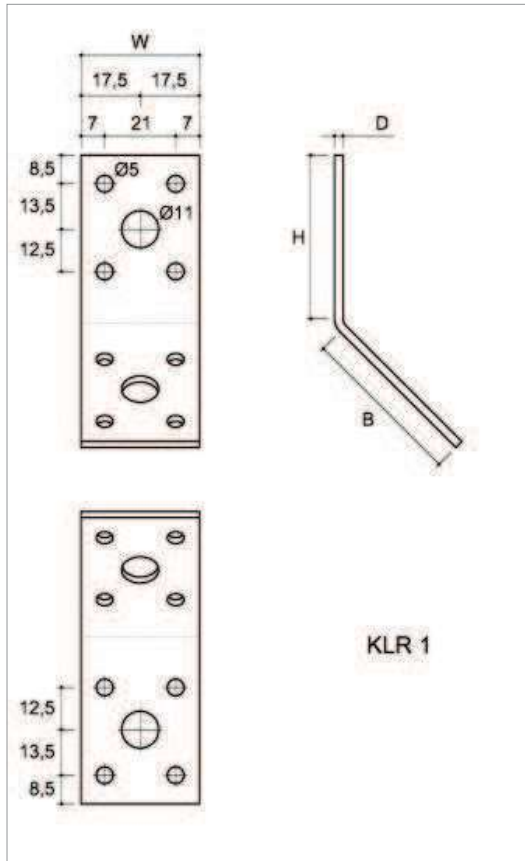


Figure 4 Type KLR 1

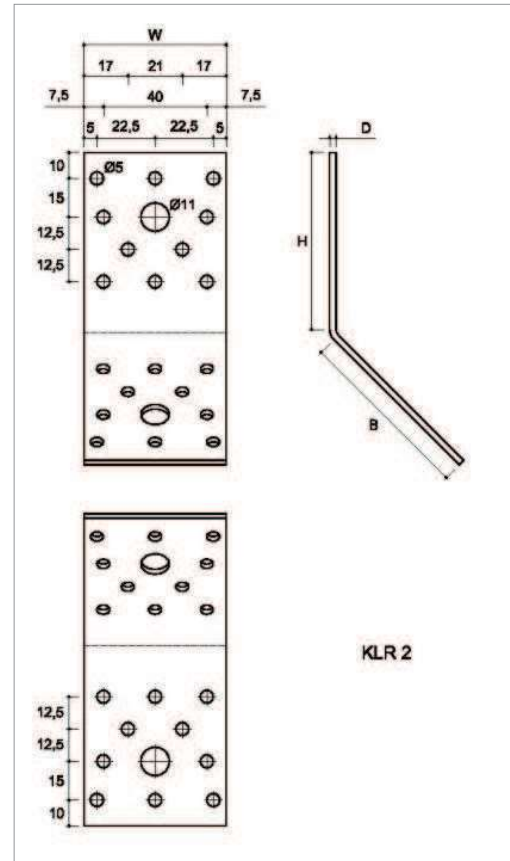


Figure 5 Type KLR 2

Table 4 KLR three-dimensional nailing plate symbols and dimensions

Symbol	Dimensions, mm				Quantity of openings	
	W	H	B	D	ø 5	ø 11
KLR 1	35	50	50	2.5	8	2
KLR 2	55	70	70	2.5	20	2

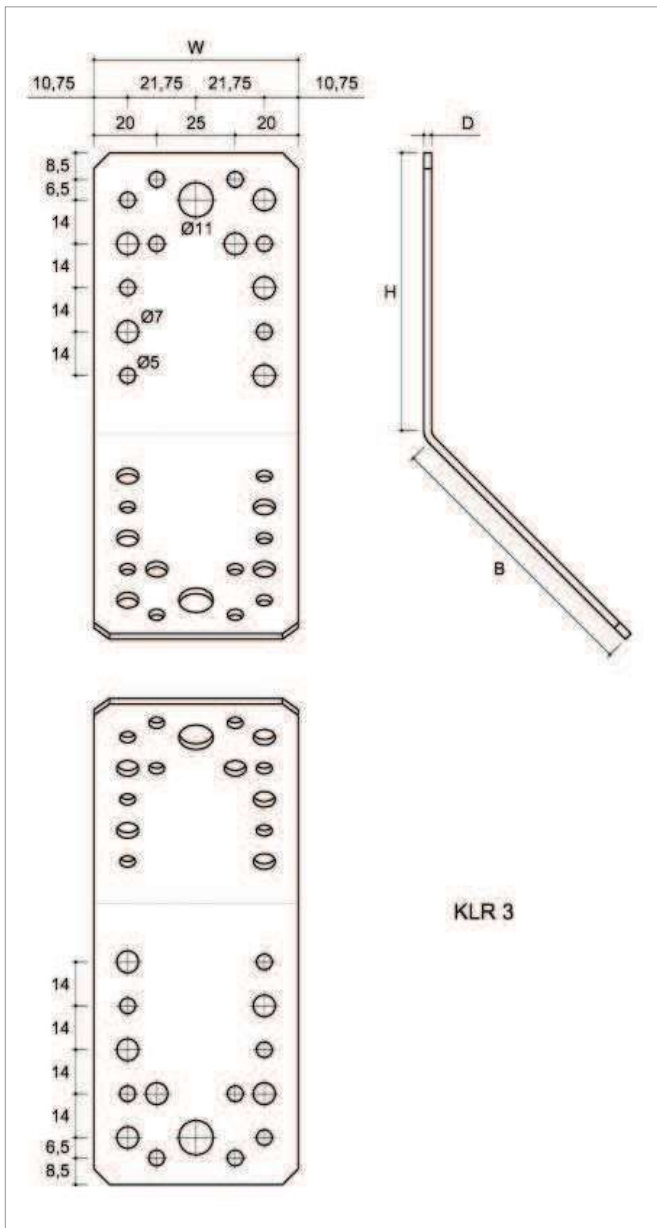


Figure 6 Type KLR 3

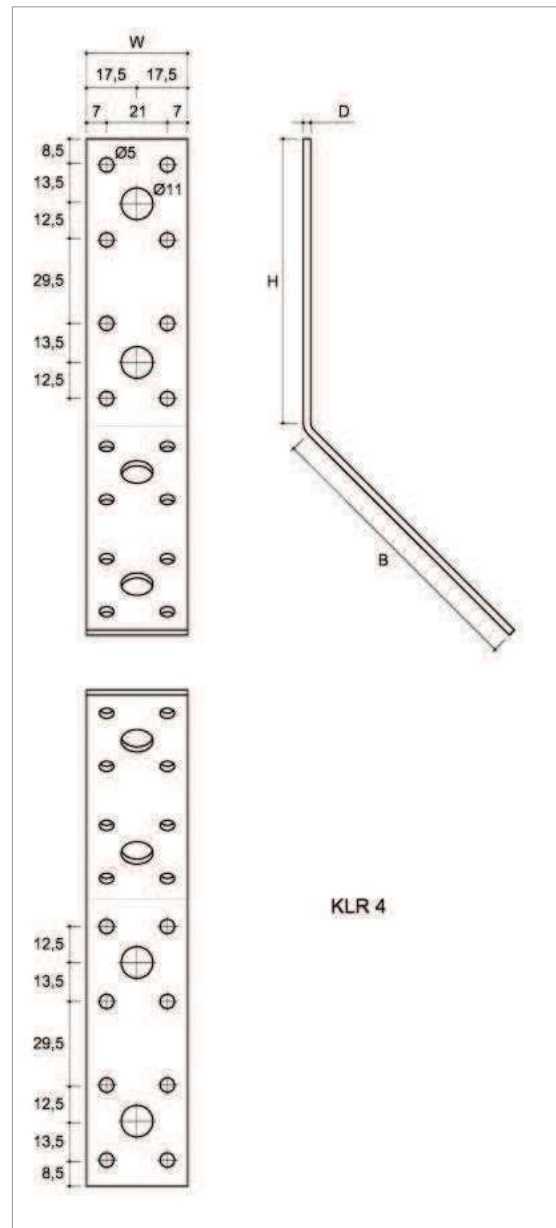


Figure 7 Type KLR 4

Table 5 KLR three-dimensional nailing plate symbols and dimensions

Symbol	Dimensions, mm				Quantity of openings		
	W	H	B	D	Ø 5	Ø 7	Ø 11
KLR 3	65	90	90	2,5	16	12	2
KLR 4	35	100	100	2,5	16	-	4

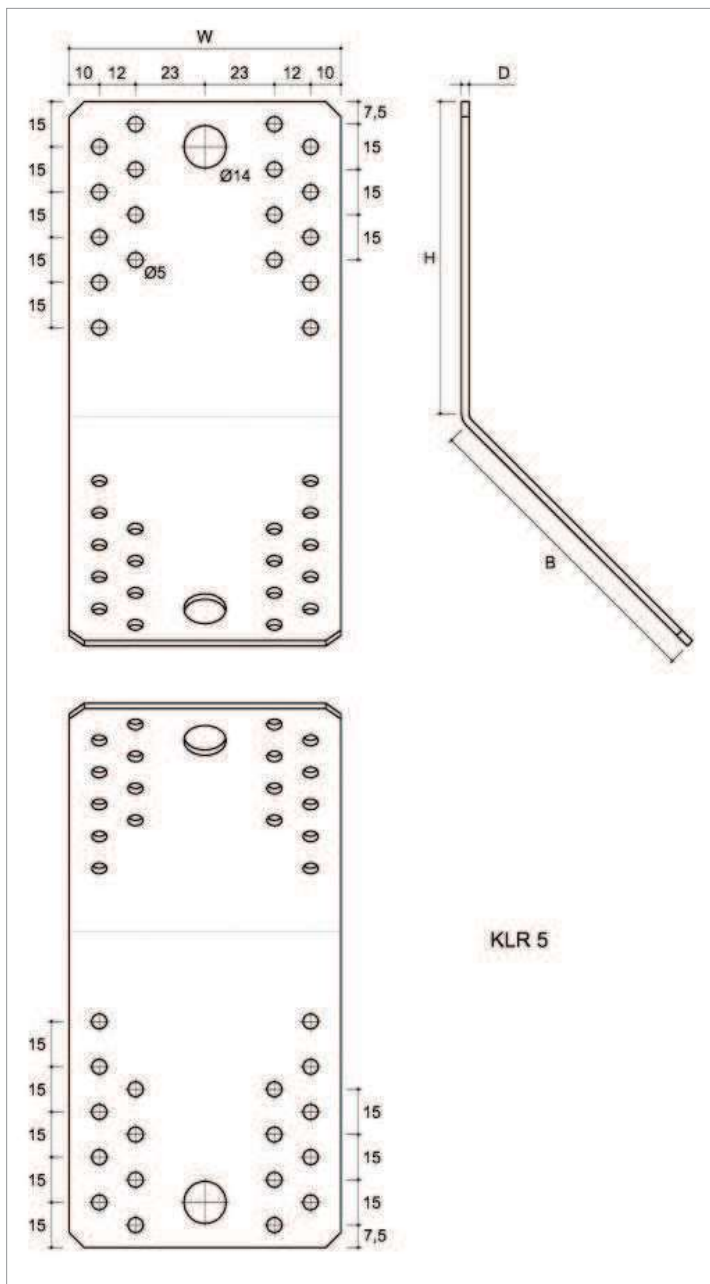


Figure 8 Type KLR 5

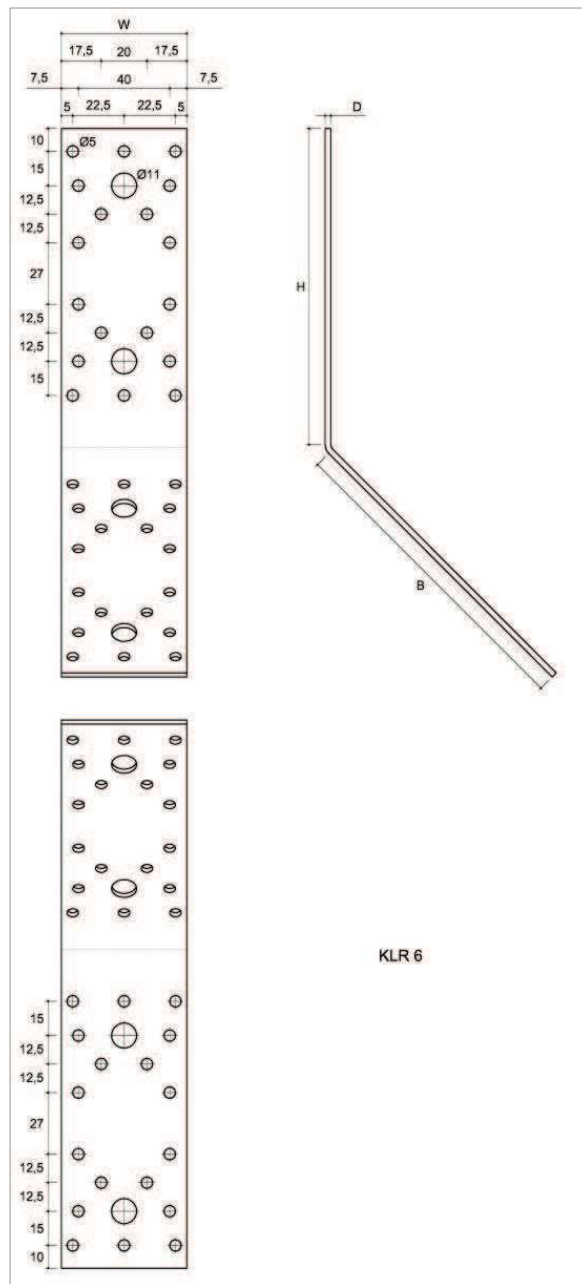


Figure 9 Type KLR 6

Table 6 KLR three-dimensional nailing plate symbols and dimensions

Symbol	Dimensions, mm				Quantity of openings		
	W	H	B	D	ø 5	ø 11	ø 14
KLR 5	90	105	105	2.5	36	-	2
KLR 6	55	140	140	2.5	36	4	-



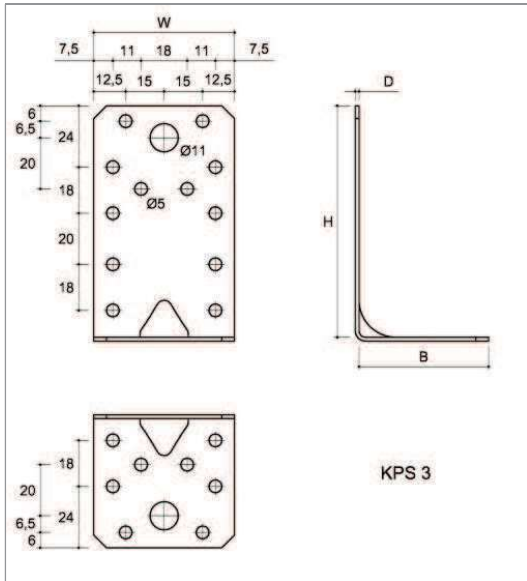


Figure 14 Type KPS 3

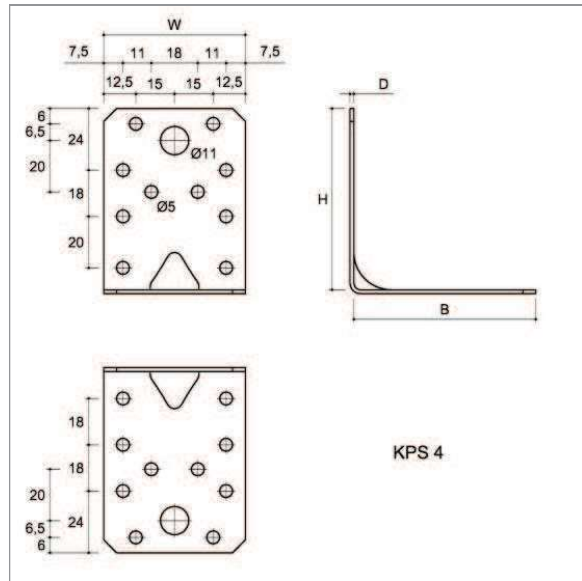


Figure 15 Type KPS 4

Table 8 KPS three-dimensional nailing plate symbols and dimensions

Symbol	Dimensions, mm				Quantity of openings			
	W	H	B	D	Ø 5	Ø 7	Ø 11	Ø 14
KPS 1	65	90	90	1,5	16	12	2	-
KPS 2	90	105	105	1,5	36	-	-	2
KPS 3	55	90	50	1,5	20	-	2	-
KPS 4	55	70	70	1,5	20	-	2	-

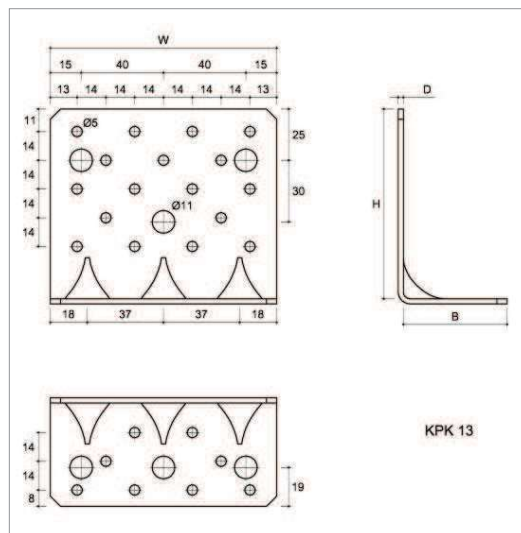


Figure 16 Type KPK 13



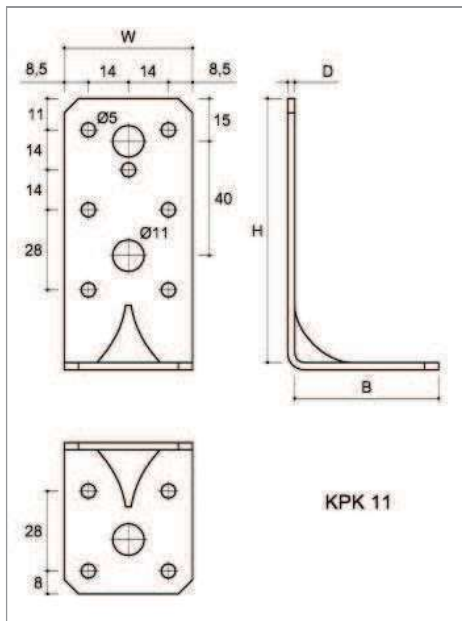


Figure 17 Type KPK 11

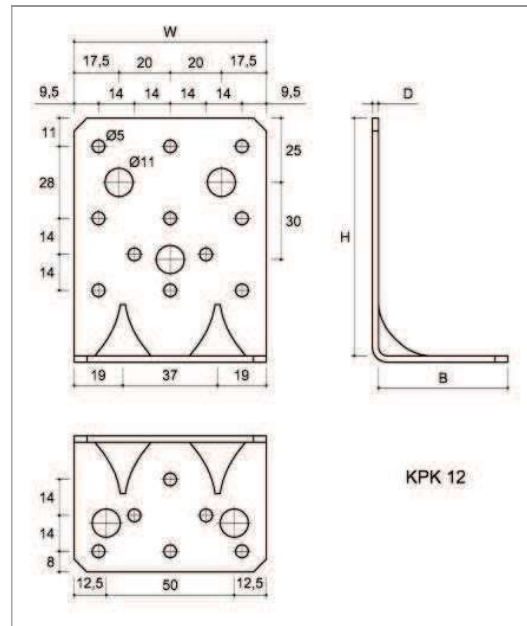


Figure 18 Type KPK 12

Table 9 KPK three-dimensional nailing plate symbols and dimensions

Symbol	Dimensions, mm				Quantity of openings	
	W	H	B	D	Ø 5	Ø 11
KPK 11	45	93	50	2.5	11	3
KPK 12	75	93	50	2.5	17	5
KPK 13	110	93	50	2.5	25	6

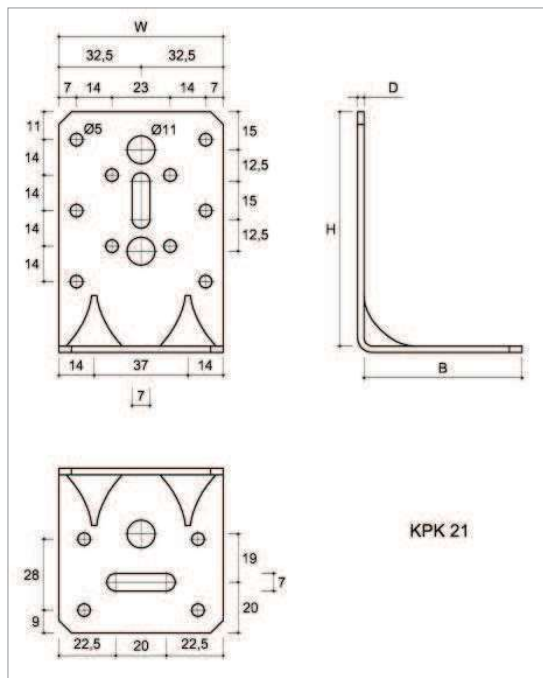


Figure 19 Type KPK 21

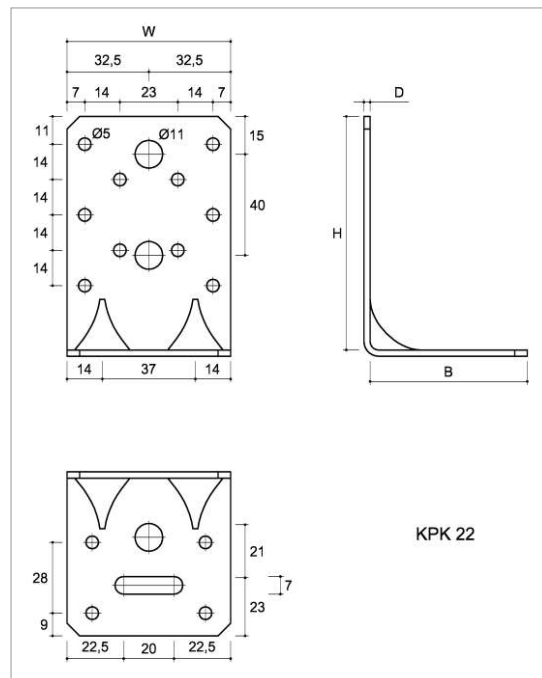


Figure 20 Type KPK 22

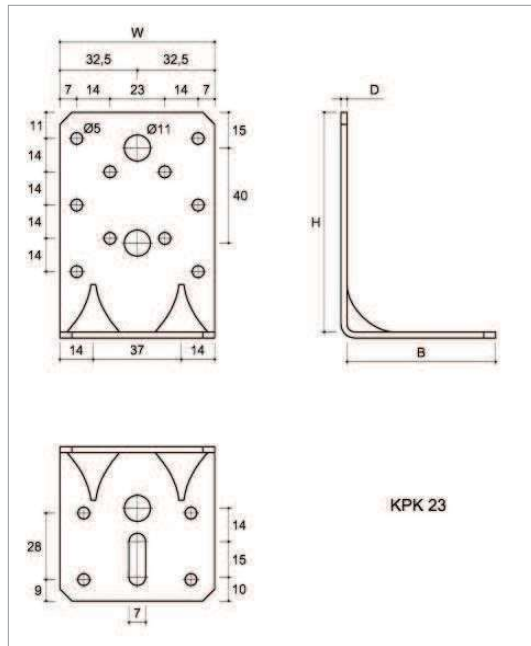


Figure 21 Type KPK 23

Table 10 KPK three-dimensional nailing plate symbols and dimensions

Symbol	Dimensions, mm				Quantity of openings	
	W	H	B	D	ø 5	ø 11
KPK 21	65	93	63	2.5	14	3
KPK 22	65	93	63	2.5	14	3
KPK 23	65	93	63	2.5	14	3

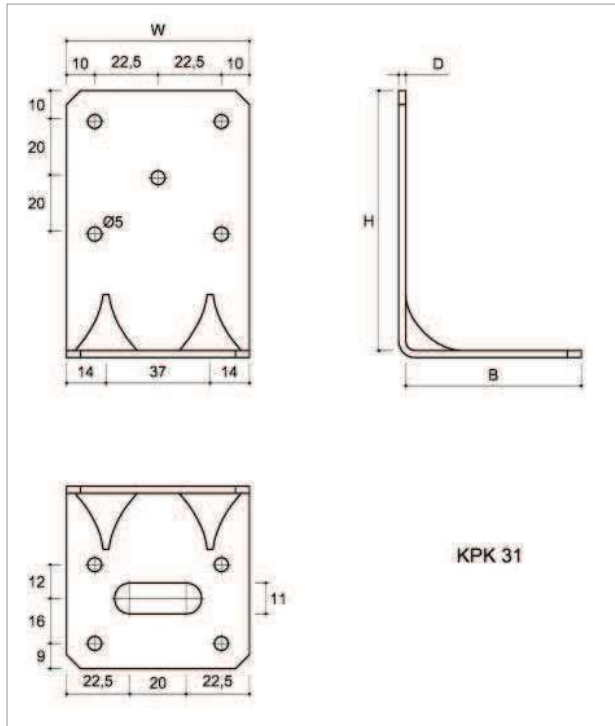


Figure 22 Type KPK 31

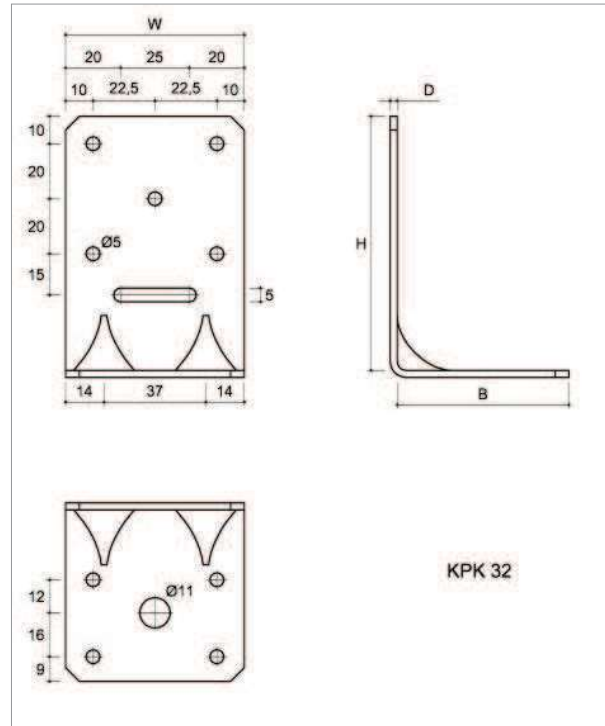


Figure 23 Type KPK 32

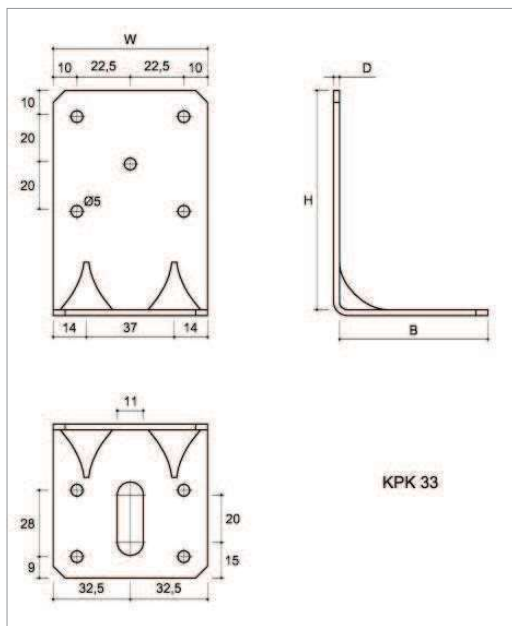


Figure 24 Type KPK 33

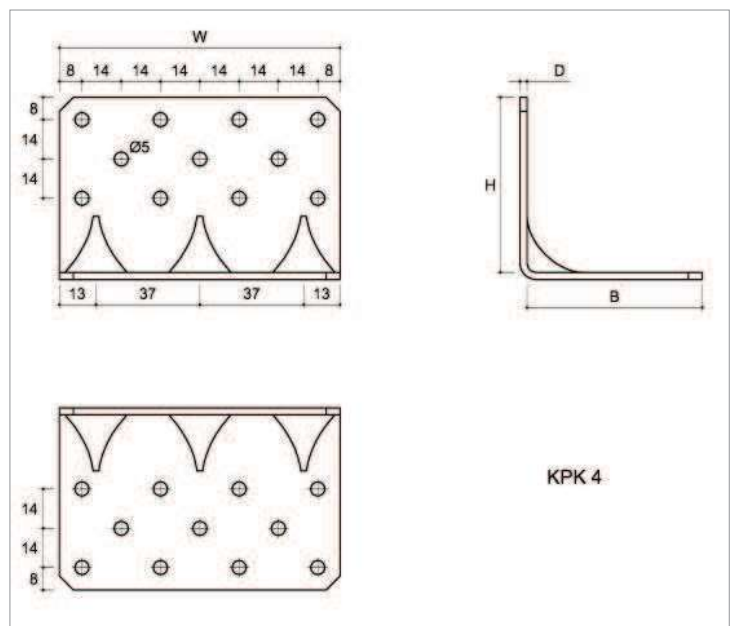


Figure 25 Type KPK 4

Table 11 KPK three-dimensional nailing plate symbols and dimensions

Symbol	Dimensions, mm				Quantity of openings	
	W	H	B	D	Ø 5	Ø 11
KPK 31	65	93	63	2.5	9	-
KPK 32	65	93	63	2.5	9	1
KPK 33	65	93	63	2.5	9	-
KPK 4	100	63	63	2.5	22	-

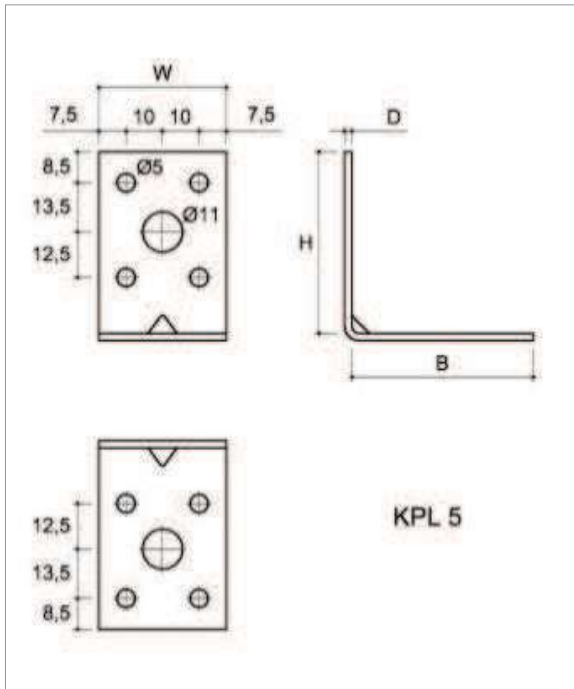


Figure 26 Type KPL 5

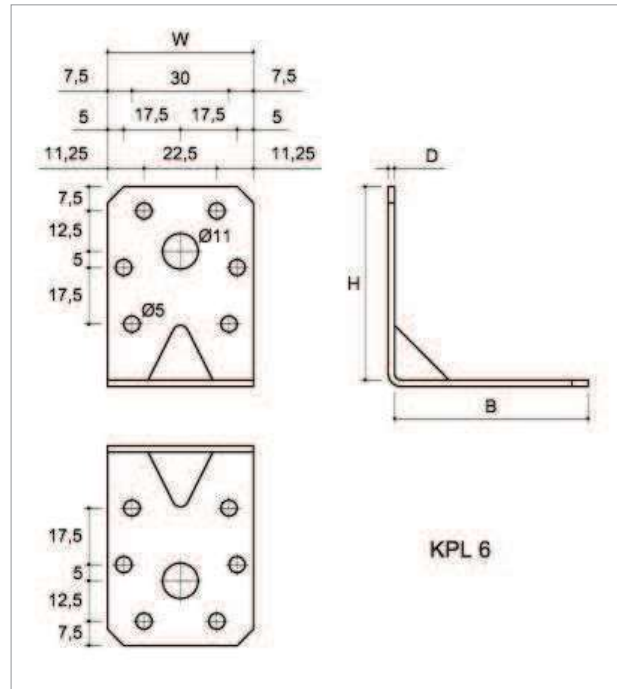


Figure 27 Type KPL 6

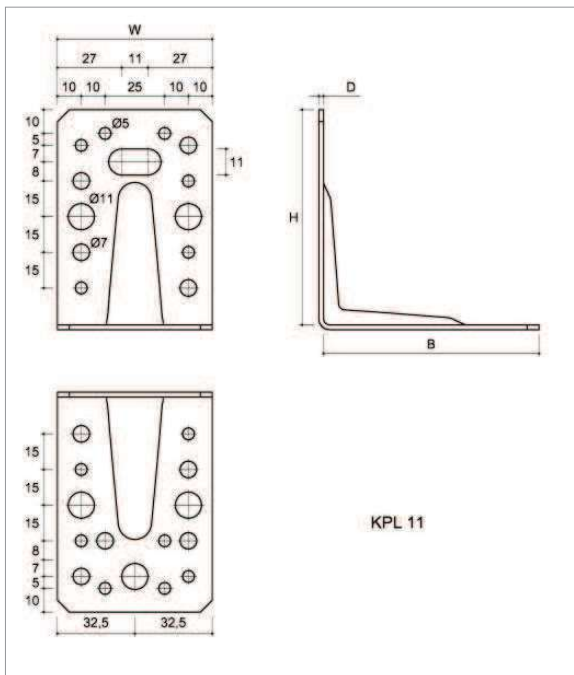


Figure 28 Type KPL 11

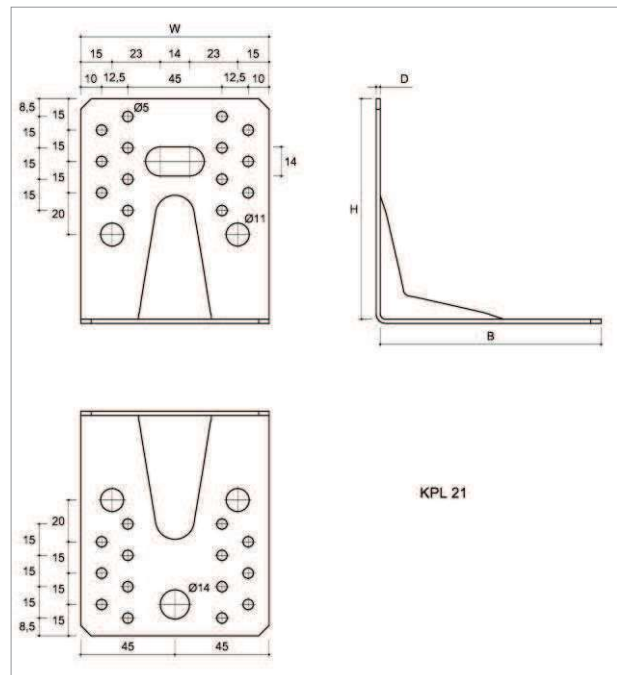


Figure 29 Type KPL 21

Table 12 KPL three-dimensional nailing plate symbols and dimensions

Symbol	Dimensions, mm				Quantity of openings			
	W	H	B	D	Ø 5	Ø 7	Ø 11	Ø 14
KPL 5	35	50	50	2	8	-	2	-
KPL 6	45	60	60	2	12	-	2	-
KPL 11	65	90	90	2	13	9	5	-
KPL 21	90	105	105	2	28	-	4	1

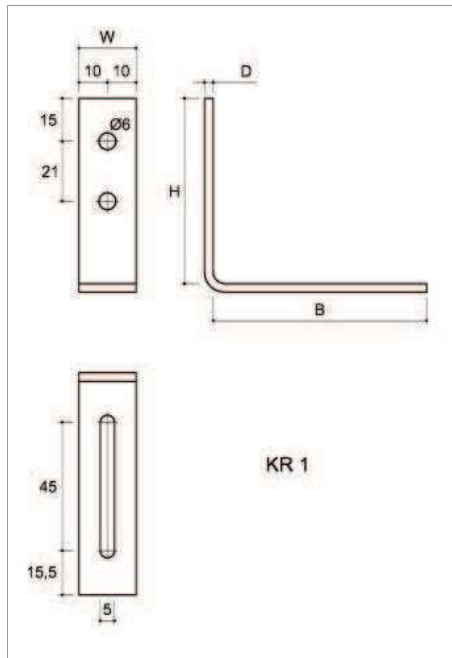


Figure 30 Type KR 1

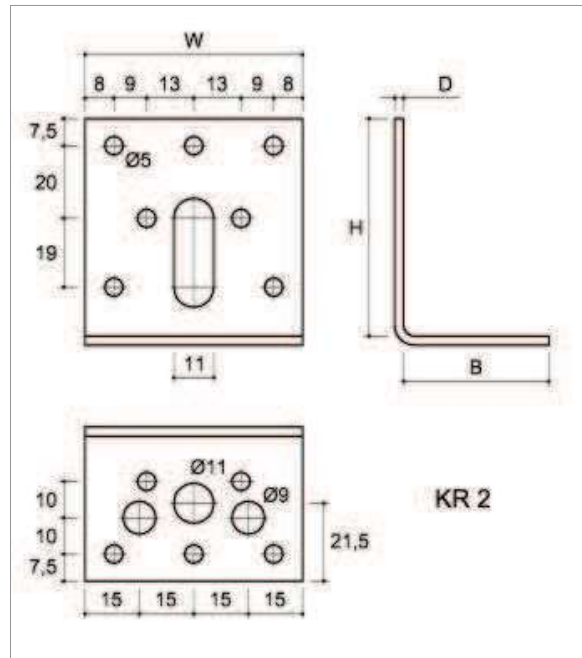


Figure 31 Type KR 2

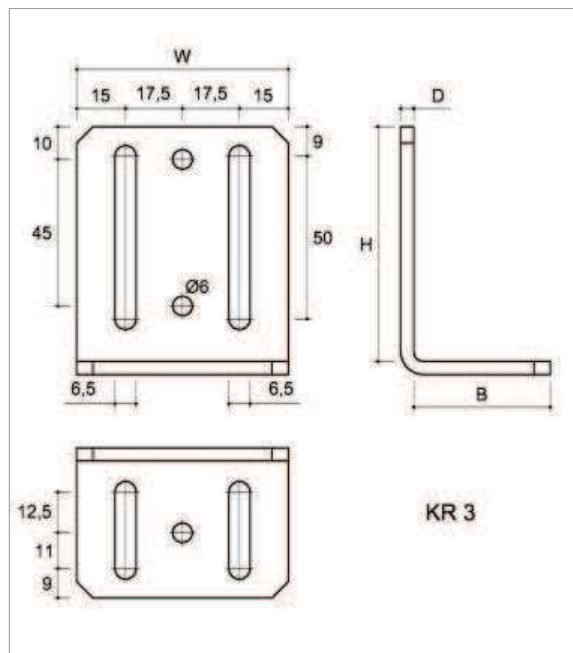


Figure 32 Type KR 3

Table 13 KR three-dimensional nailing plate symbols and dimensions

Symbol	Dimensions, mm				Quantity of openings			
	W	H	B	D	Ø 5	Ø 6	Ø 9	Ø 11
KR 1	20	65	75	3	-	2	-	-
KR 2	60	60	40	2.5	12	-	2	1
KR 3	65	72	42	4	-	3	-	-

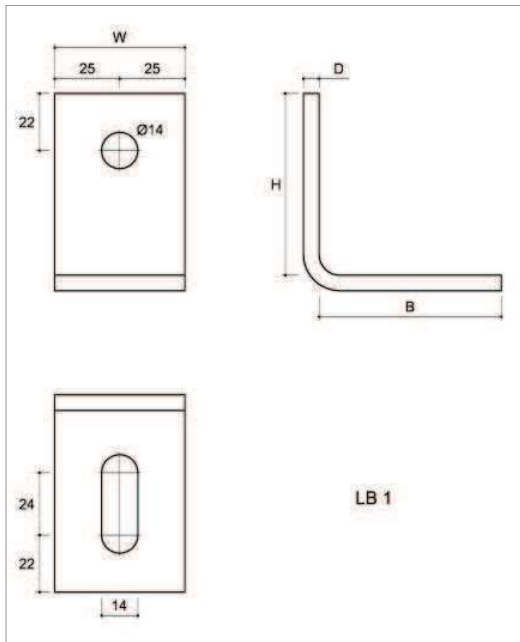


Figure 33 Type LB 1

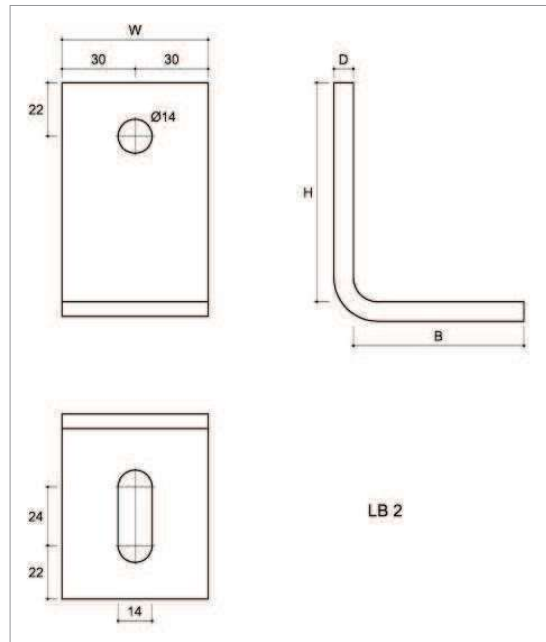


Figure 34 Type LB 2

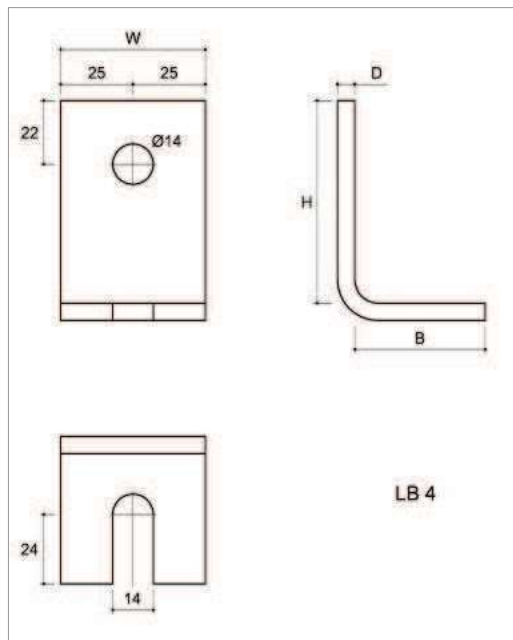


Figure 35 Type LB 4

Table 14 LB three-dimensional nailing plate symbols and dimensions

Symbol	Dimensions, mm				Quantity of openings
	W	H	B	D	Ø 14
LB 1	50	70	70	6	1
LB 2	60	90	70	8	1
LB 4	50	70	45	6	1



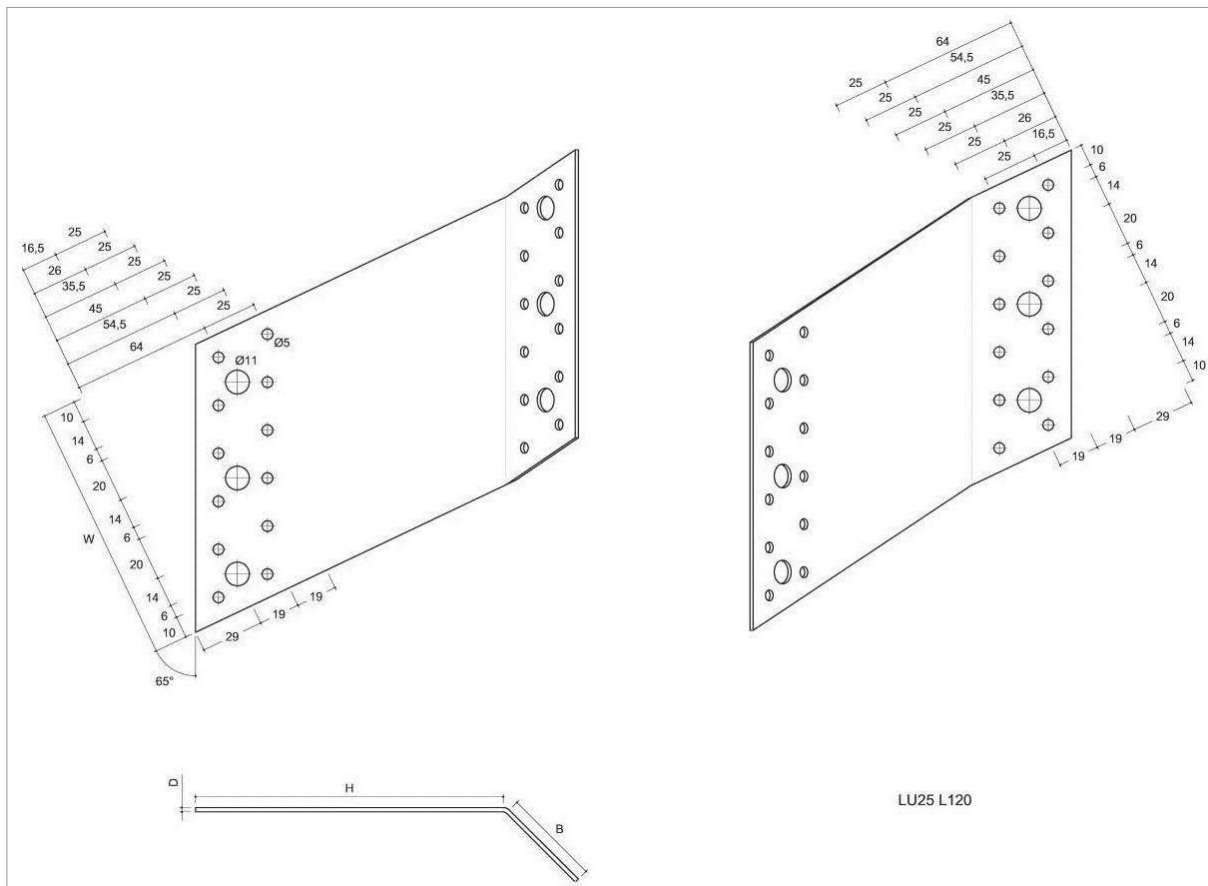
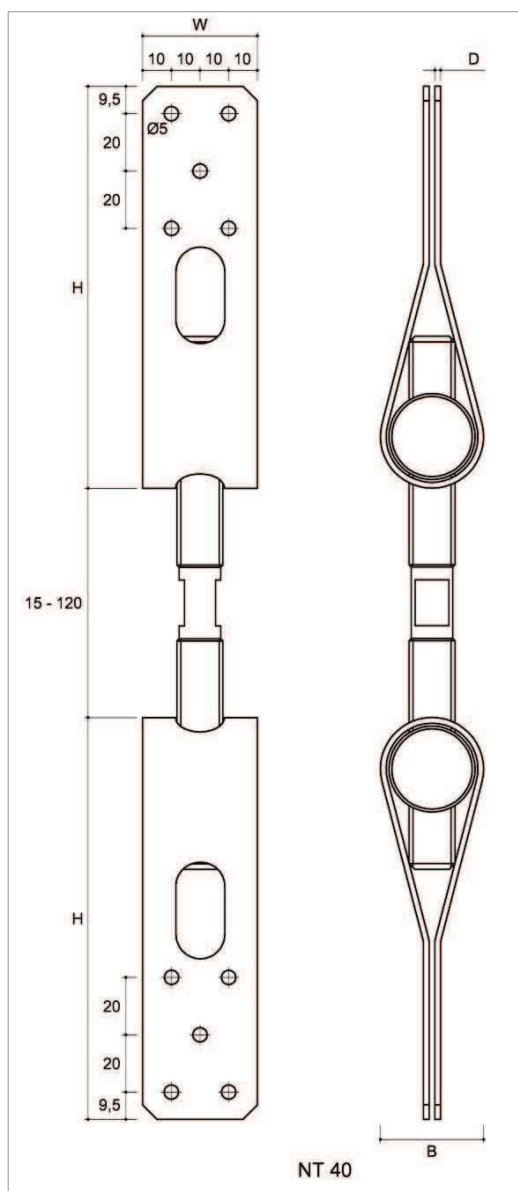


Figure 36 Type LU25 L120

Table 15 LU25 three-dimensional nailing plate symbols and dimensions

Symbol	Dimensions, mm				Quantity of openings	
	W	H	B	D	∅ 5	∅ 11
LU25 L80	80	142	45	2	16	4
LU25 R80	80	142	45	2	16	4
LU25 L120	120	142	45	2	24	6
LU25 R120	120	142	45	2	24	6



**Figure 37** Type NT 40

**Table 16** NT three-dimensional nailing plate symbols and dimensions

Symbol	Dimensions, mm				Quantity of openings
	W	H	B	D	Ø 5
NT 25	30	137	25	1.5	12
NT 40	40	140	36	2	10
NT 60	60	140	36	2	14

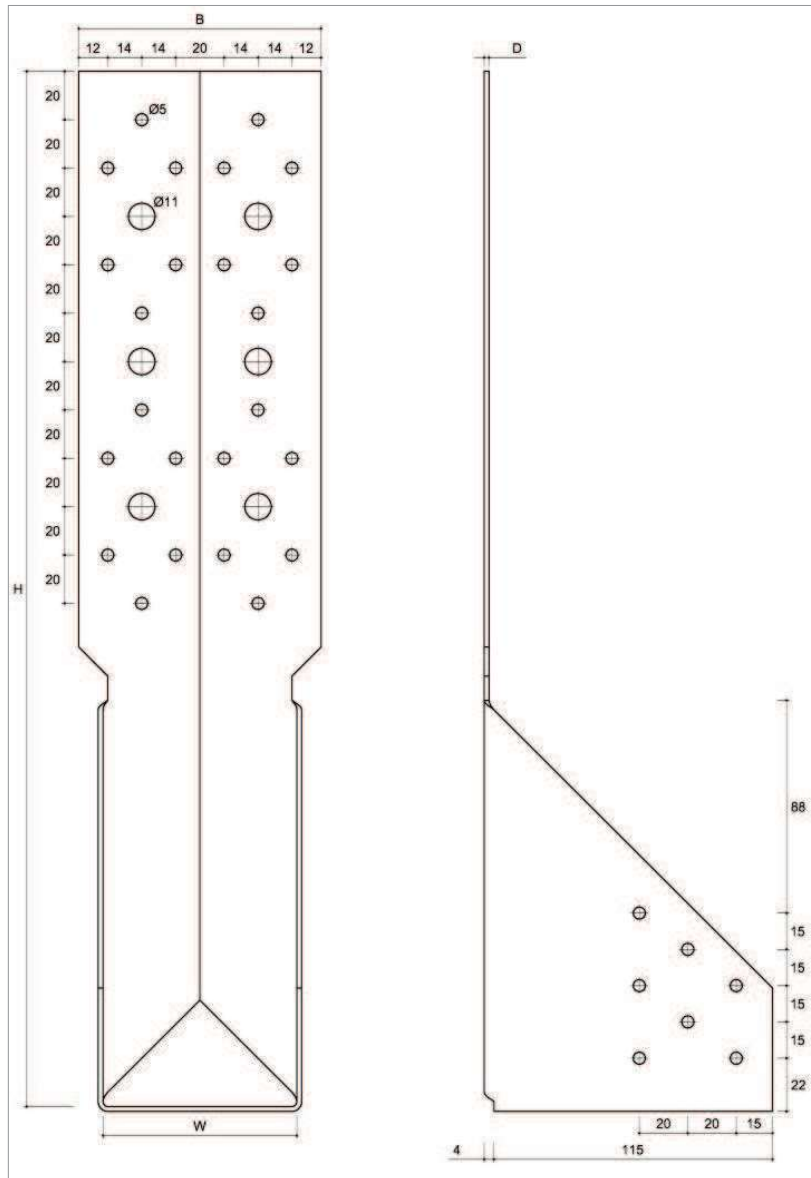


Figure 38 Type WBC 80

Table 17 WBC three-dimensional nailing plate symbols and dimensions

Symbol	Dimensions, mm				Quantity of openings	
	W	H	B	D	ø 5	ø 11
WBC 80	80	428	100	2	38	6
WBC 92	92	443	114	2	42	8
WBC 100	100	443	120	2	42	8
WBC 120	120	505	148	2	48	10
WBC 137	137	515	160	2	52	12

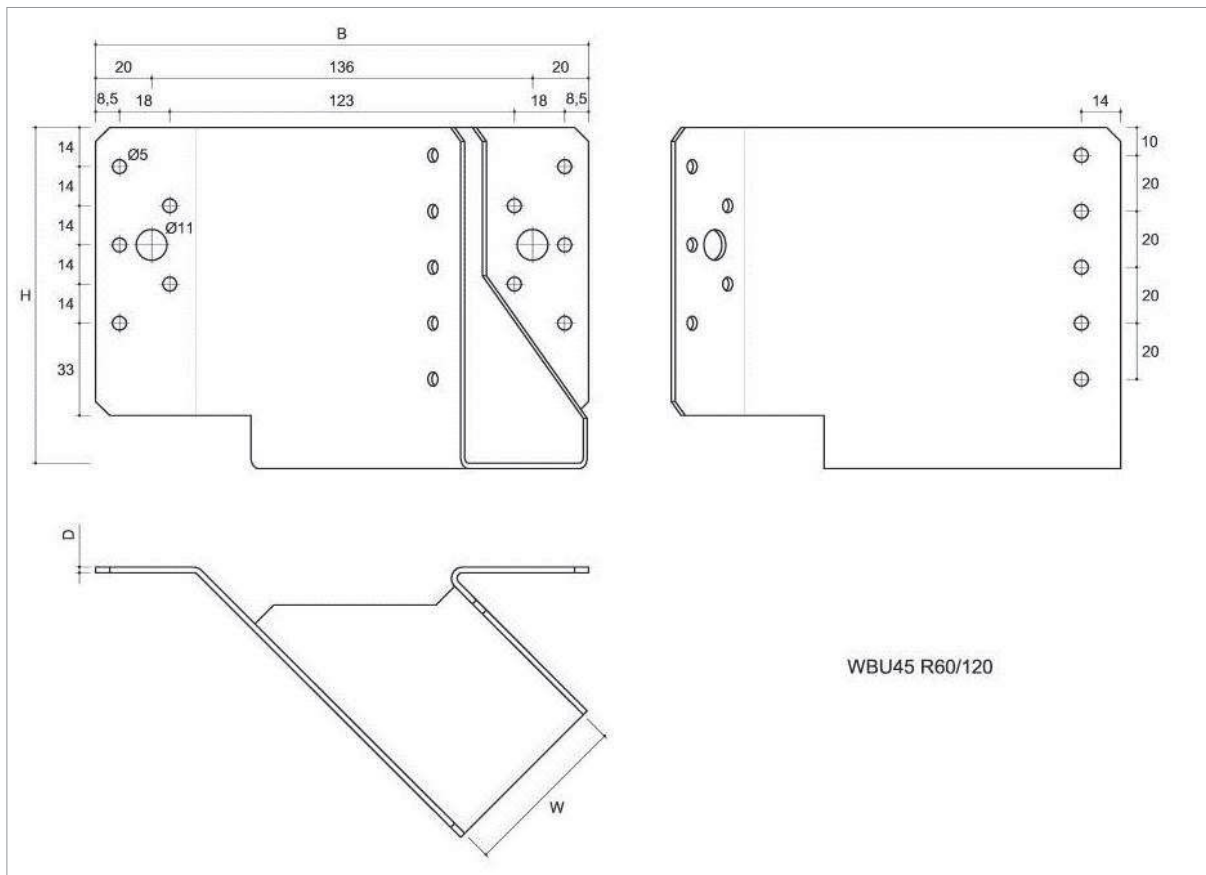


Figure 39 Type WBU 45 R60/120

Table 18 WBU 45 three-dimensional nailing plate symbols and dimensions

Symbol	Dimensions, mm				Quantity of openings	
	W	H	B	D	Ø 5	Ø 11
WBU45 R45/105 WBU45 L45/105	45	105	155	2	12	2
WBU45 R50/105 WBU45 L50/105	50	105	162	2	12	2
WBU45 R60/120 WBU45 L60/120	60	120	176	2	15	2

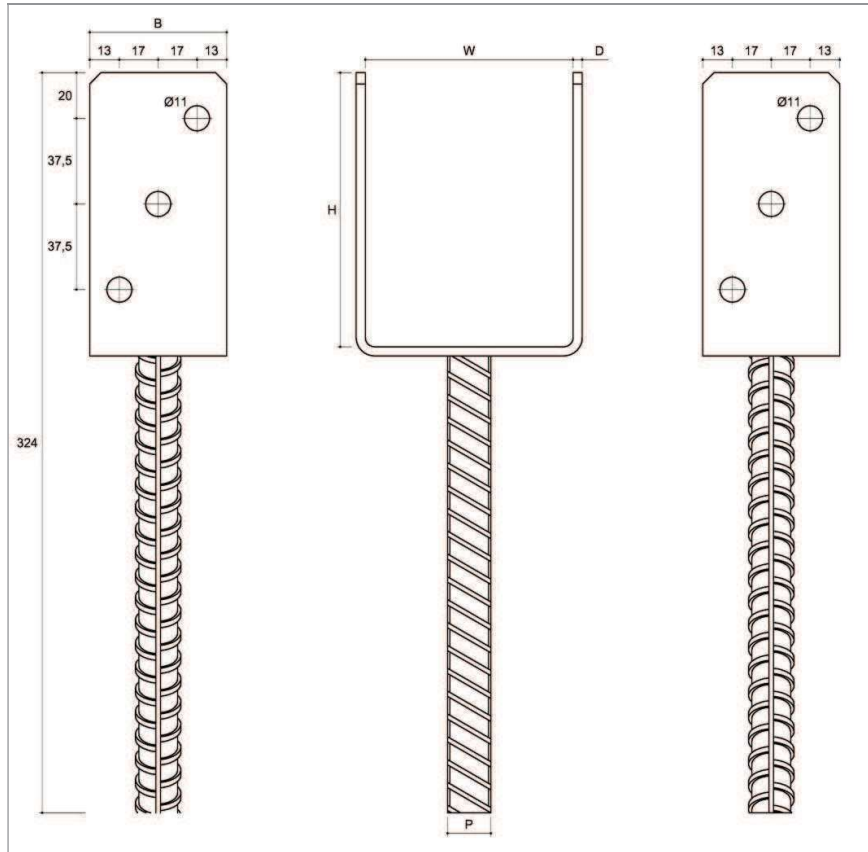


Figure 40 Type PS 90

Table 19 PS three-dimensional nailing plate symbols and dimensions

Symbol	Dimensions, mm					Quantity of openings
	W	H	B	D	P	Ø 11
PS 60	61	120	60	4	Ø 16	6
PS 70	71	120	60	4	Ø 16	6
PS 80	81	120	60	4	Ø 18	6
PS 90	91	120	60	4	Ø 18	6
PS 100	101	120	60	4	Ø 18	6
PS 120	121	120	60	4	Ø 18	6
PS 140	141	120	60	4	Ø 18	6

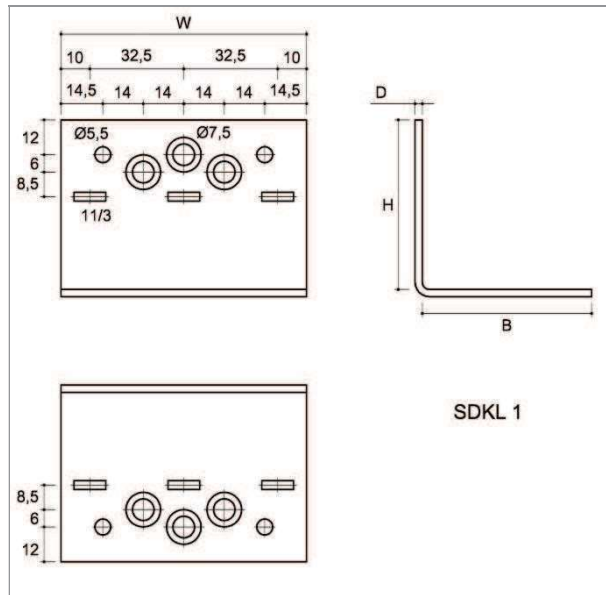


Figure 41 Type SDKL 1

Table 20 SDKL three-dimensional nailing plate symbols and dimensions

Symbol	Dimensions, mm				Quantity of openings		
	W	H	B	D	Ø 5.5	Ø 7.5	11/3
SDKL 1	85	58	58	2,5	4	6	6

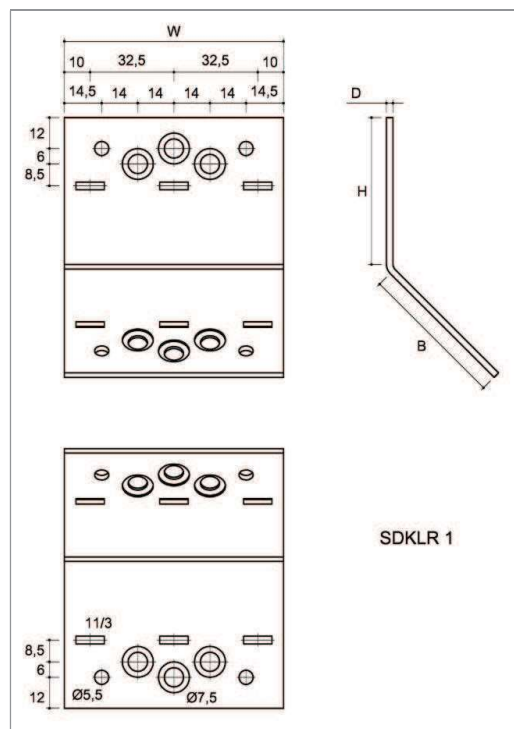


Figure 42 Type SDKLR 1

Table 21 SDKLR three-dimensional nailing plate symbols and dimensions

Symbol	Dimensions, mm				Quantity of openings		
	W	H	B	D	Ø 5.5	Ø 7.5	11/3
SDKLR 1	85	57	57	2,5	4	6	6



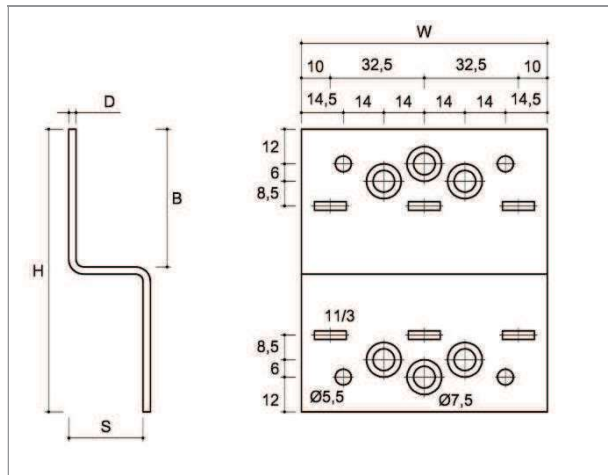


Figure 43 Type SDLZ 1

Table 22 SDLZ 1 three-dimensional nailing plate symbols and dimensions

Symbol	Dimensions, mm					Quantity of openings		
	W	H	B	S	D	ø 5.5	ø 7.5	11/3
SDLZ 1	85	96,5	47	24	2,5	4	6	6

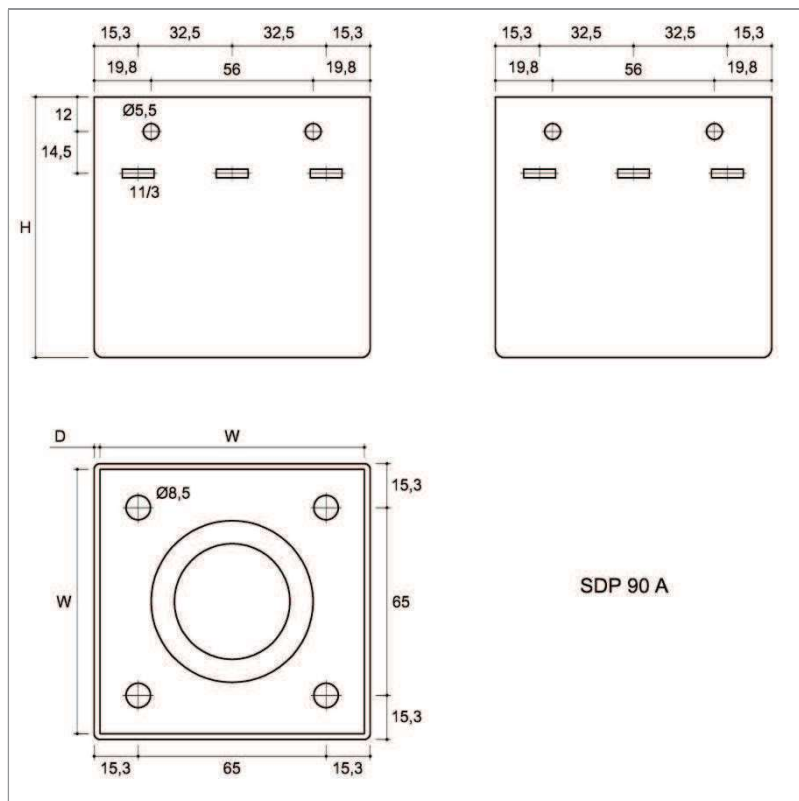


Figure 44 Type SDP 90 A

Table 23 SDP 90 A three-dimensional nailing plate symbols and dimensions

Symbol	Dimensions, mm			Quantity of openings		
	W	H	D	ø 5.5	ø 8.5	11/3
SDP 90 A	91	90	2	8	4	12
SDP 100 A	101	90	2	8	4	12
SDP 120 A	121	90	2	8	4	12

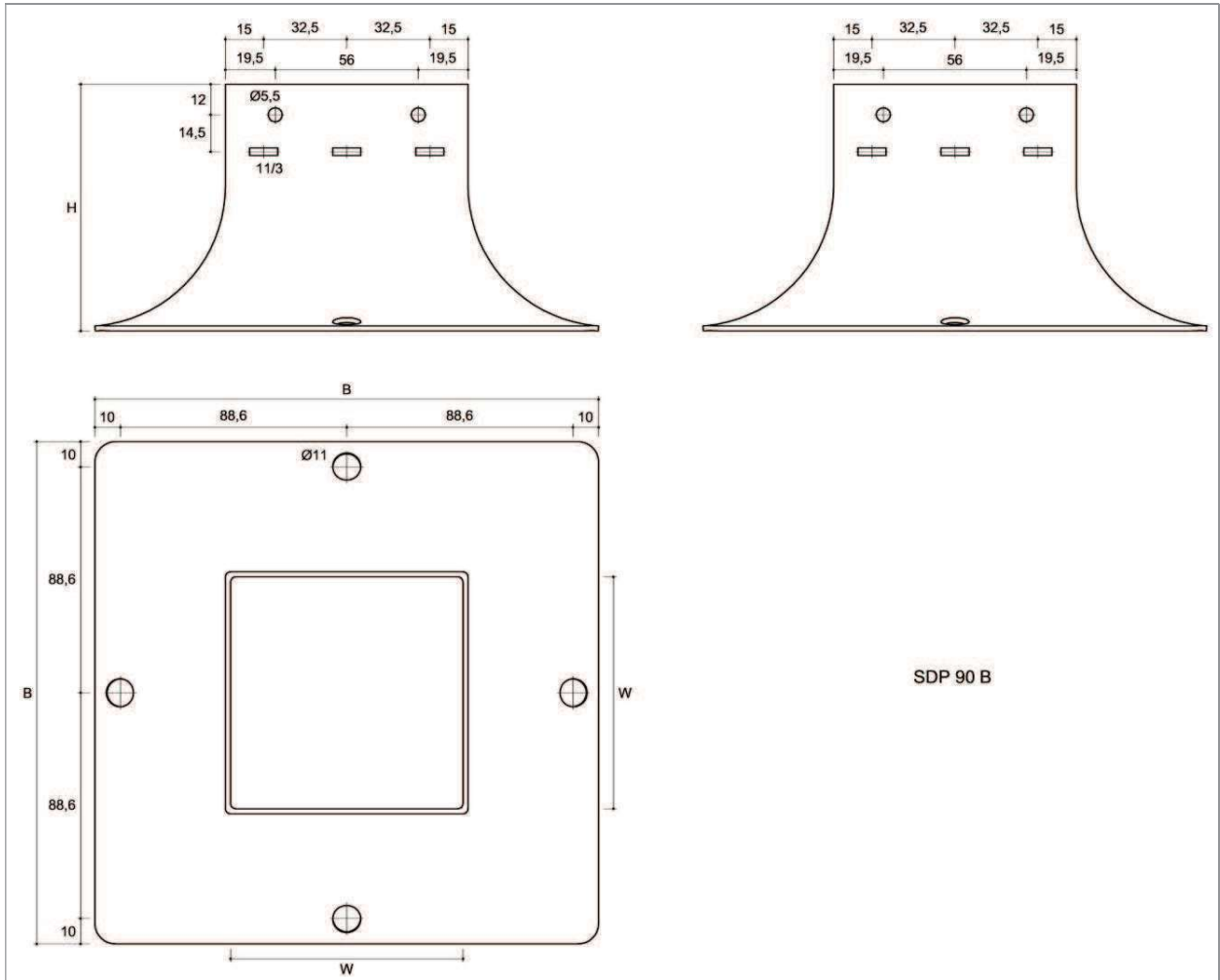


Figure 45 Type SDP 90 B

Table 24 SDP 90 B three-dimensional nailing plate symbols and dimensions

Symbol	Dimensions, mm				Quantity of openings		
	W	H	D	B	∅ 5.5	∅ 11	11/3
SDP 90 B	91	97	2	197	8	4	12
SDP 100 B	101	97	2	207	8	4	12
SDP 120 B	121	97	2	227	8	4	12

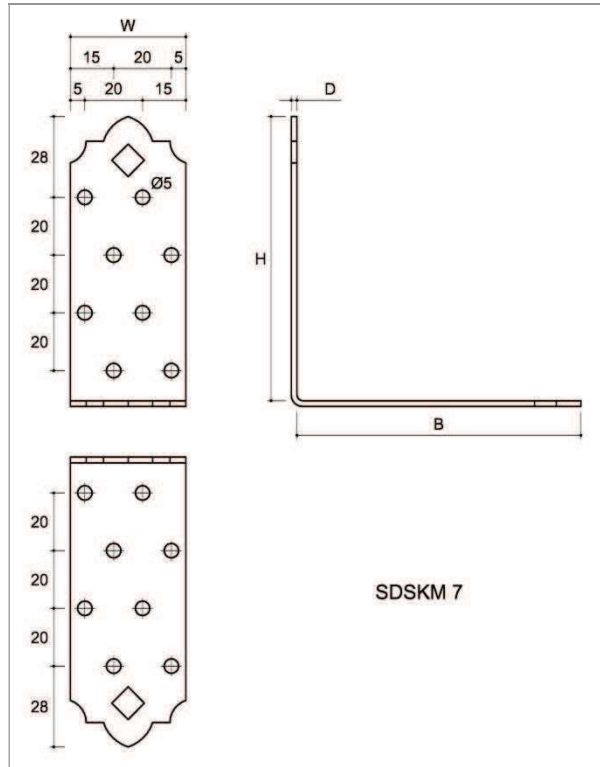


Figure 46 Type SDSKM 7

Table 25 SDSKM three-dimensional nailing plate symbols and dimensions

Symbol	Dimensions, mm				Quantity of openings
	W	H	B	D	Ø 5
SDSKM 7	40	98	98	2	16

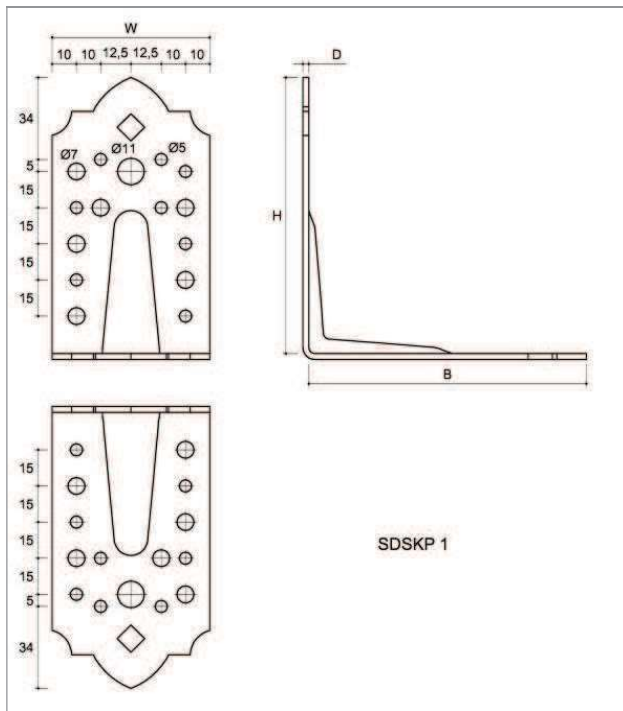


Figure 47 Type SDSKP 1

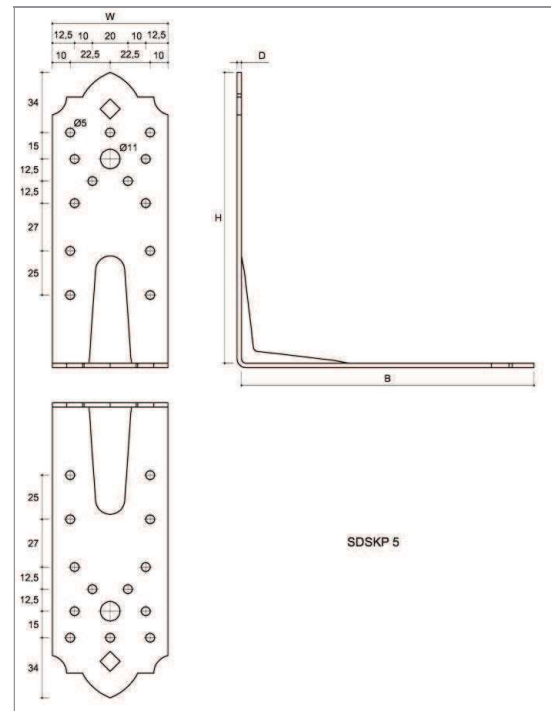


Figure 48 Type SDSKP 5

Table 26 SDSKP three-dimensional nailing plate symbols and dimensions

Symbol	Dimensions, mm				Quantity of openings		
	W	H	B	D	ø 5	ø 7	ø 11
SDSKP 1	65	115	115	2,5	16	12	2
SDSKP 5	65	165	165	2,5	26	-	2

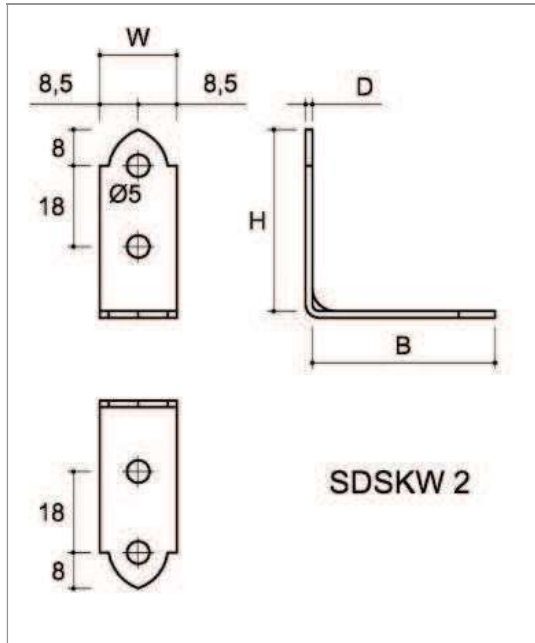


Figure 49 Type SDSKW 2

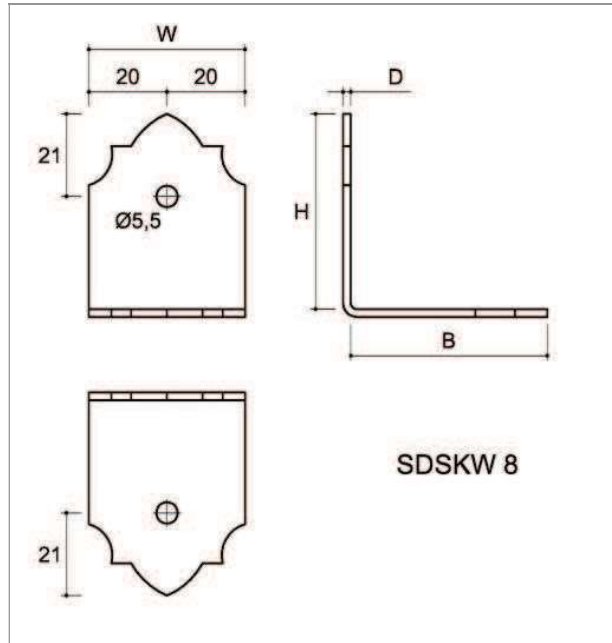
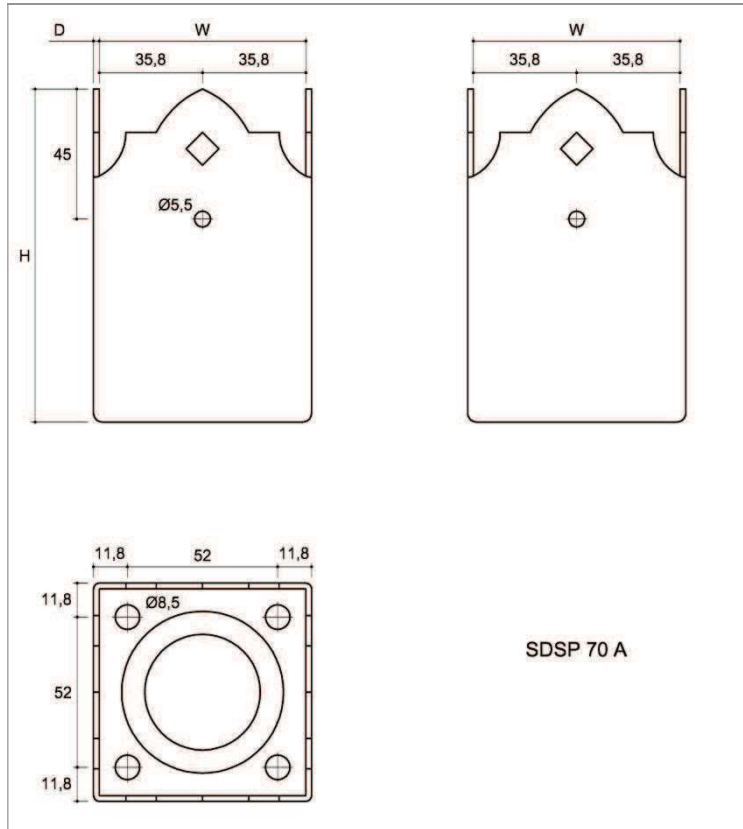


Figure 50 Type SDSKW 8

Table 27 SDSKW three-dimensional nailing plate symbols and dimensions

Symbol	Dimensions, mm				Quantity of openings	
	W	H	B	D	Ø 5	Ø 5.5
SDSKW 2	17	40	40	1,5	4	-
SDSKW 8	40	50	50	2	-	2

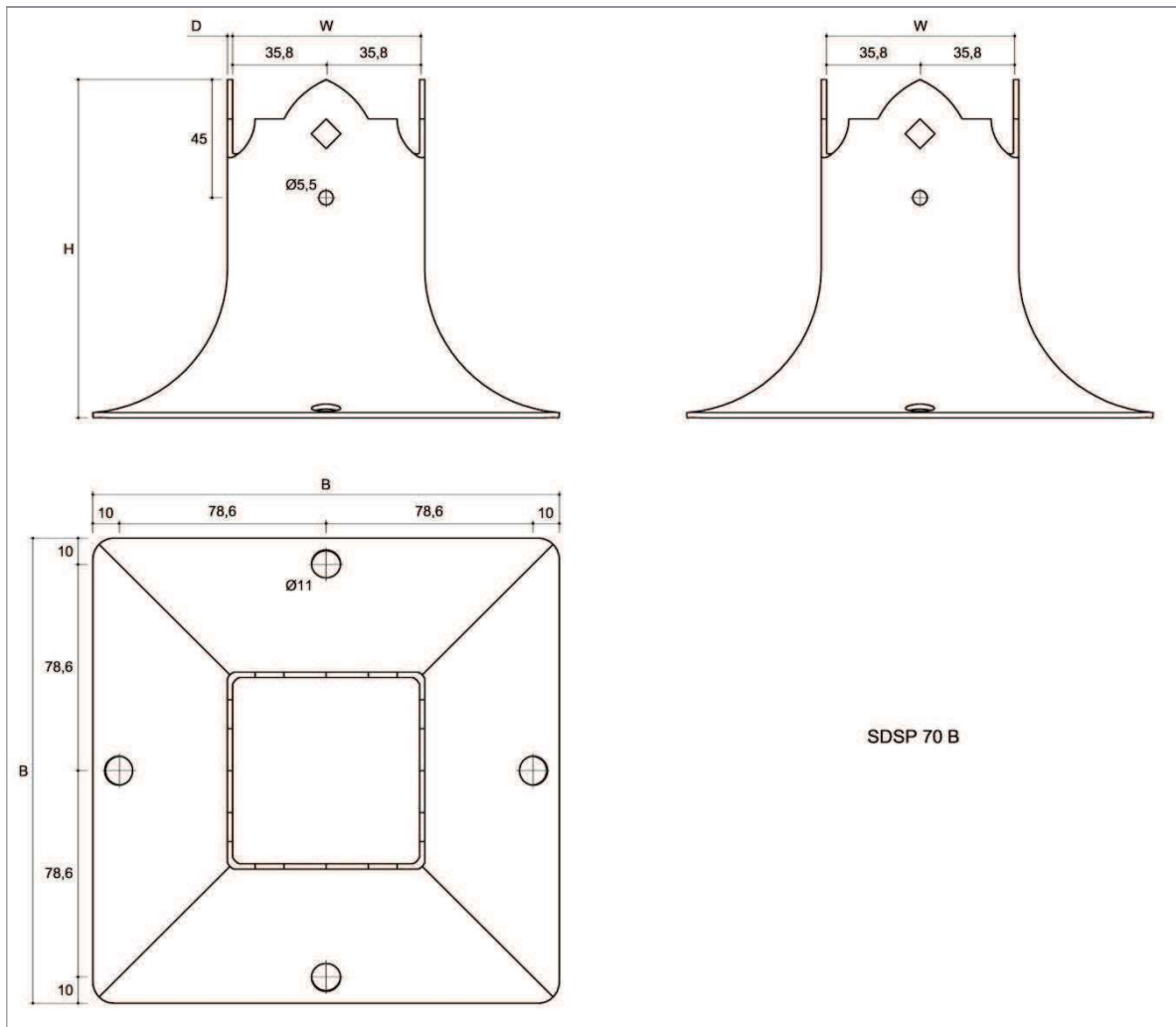


**Figure 51** Type SDSP 70 A

**Table 28** SDSP three-dimensional nailing plate symbols and dimensions

Symbol	Dimensions, mm			Quantity of openings	
	W	H	D	$\varnothing 5.5$	$\varnothing 8.5$
SDSP 70 A	71	115	2	4	4





**Figure 52** Type SDSP 70B

**Table 29** SDSP three-dimensional nailing plate symbols and dimensions

Symbol	Dimensions, mm				Quantity of openings	
	W	H	D	B	$\varnothing 5.5$	$\varnothing 11$
SDSP 70 B	71	129	2	177	4	4

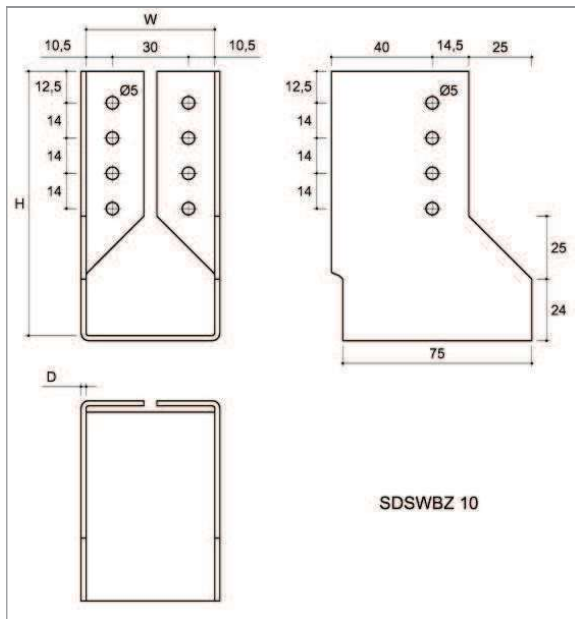


Figure 53 Type SDSWBZ 10

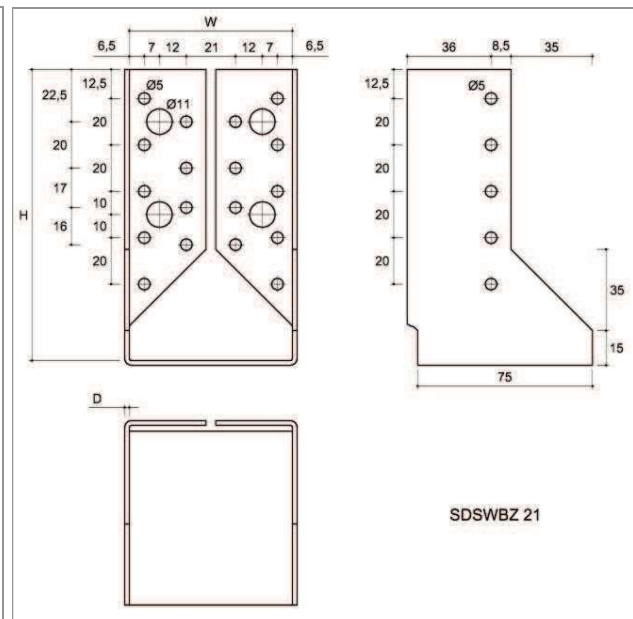


Figure 54 Type SDSWBZ 21

Table 30 SDSWBZ three-dimensional nailing plate symbols and dimensions

Symbol	Dimensions, mm			Quantity of openings	
	W	H	D	ø 5	ø 11
SDSWBZ 10	51	105	2	16	-
SDSWBZ 11	51	135	2	24	-
SDSWBZ 14	60	100	2	16	-
SDSWBZ 21	70	125	2	28	4
SDSWBZ 26	80	120	2	28	4
SDSWBZ 30	100	140	2	34	4

## MASKING ELEMENTS

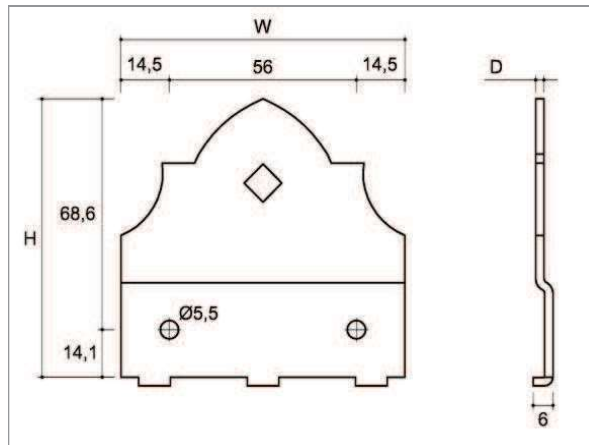


Figure 55 Type SDD 85 A

Table 31 SDD masking elements symbols and dimensions

Symbol	Dimensions, mm			Quantity of openings
	W	H	D	Ø 5.5
SDD 85 A	85	83	2,5	2
SDD 85 B	85	83	2,5	2

## CONNECTION ELEMENTS

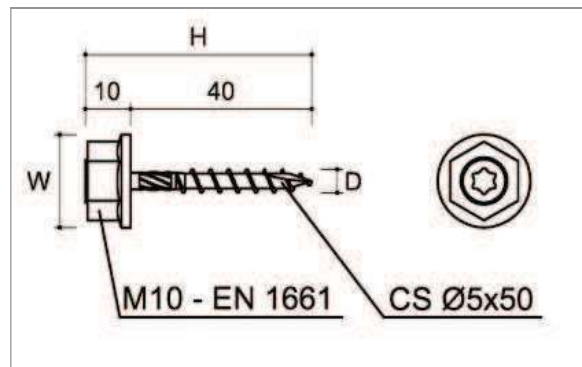


Figure 56 Type SDCS 50

Table 32 SDCS dowel type connector symbols and dimensions

Symbol	Dimensions, mm		
	W	H	D
SDCS 50	20.5	50	5.2

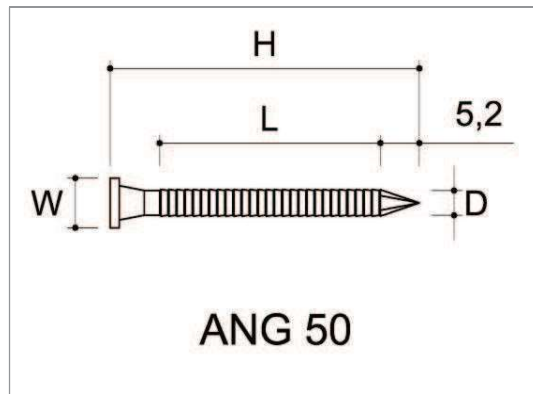


Figure 57 Type ANG 50

Table 33 Anchor dowel type connector symbols and dimensions

Symbol	Dimensions, mm			
	D	H	L	W
ANG 40	4	40	26.8	8
ANG 50	4	50	36.8	8

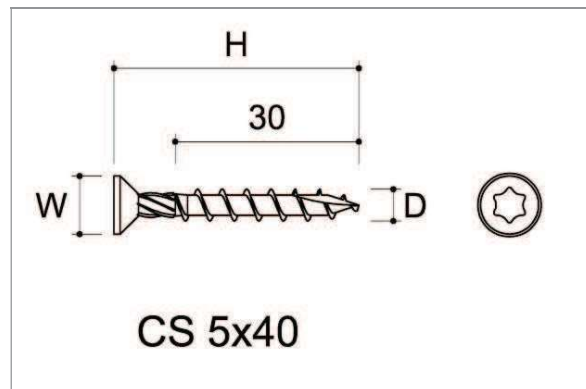


Figure 58 Type CS 5x40

Table 34 CS dowel type connector symbols and dimensions

Symbol	Dimensions, mm		
	D	H	W
CS 5x40	5	40	9.5
CS 5x50	5	50	9.5

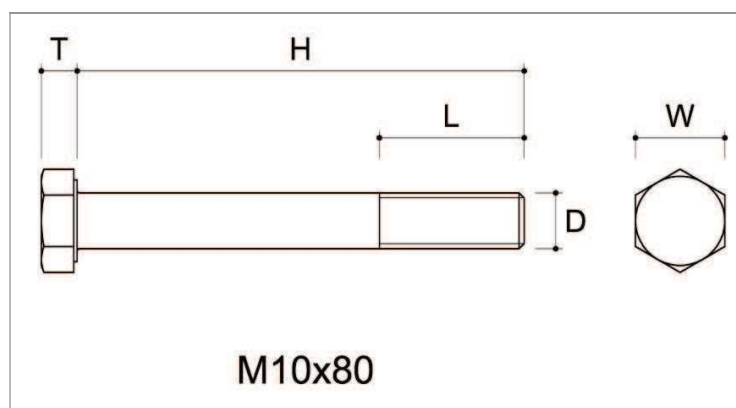
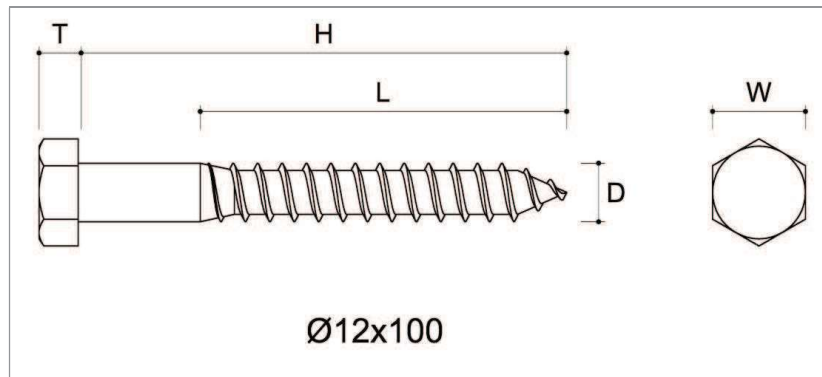


Figure 59 Type M10x80

**Table 35** M bolt type connector symbols and dimensions

Symbol	Dimensions, mm					Standard
	D	H	L	W	T	
M5x16	M5	16	16	8	3.5	ISO 4017
M10x80	M10	80	26	16	6.4	ISO 4014
M12x90	M12	90	30	18	7.5	ISO 4014
M16x160	M16	160	44	24	10	ISO 4014



**Figure 60** Type Ø12x100

**Table 36** Ø12x100 type connector symbols and dimensions

Symbol	Dimensions, mm					Standard
	D	H	L	W	T	
Ø12x100	12	100	75	19	8	DIN 571

## ANNEX 2

### LOADING ACCORDING TO STATIC DIAGRAMS

(for selected elements)

No.	Scheme	Connector types
1		<p>KPK 11, 12, 13, 21, 22, 23</p> <p>KPL 5, 6, 11, 21</p> <p>KR 1, 2, 3</p> <p>KRD 5, 6</p>

**Figure 61** Scheme 1

No.	Scheme	Connector types
2		<p>KPK 31</p> <p>KPK 32</p> <p>KPK 33</p>

**Figure 62** Scheme 2

No.	Scheme	Connector types
3		<p>KP 7</p> <p>KP 8</p>

**Figure 63** Scheme 3

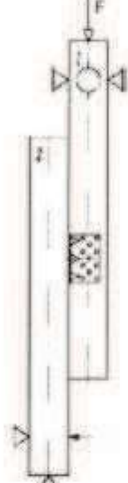
No.	Scheme	Connector types
4		KPK 4

Figure 64 Scheme 4

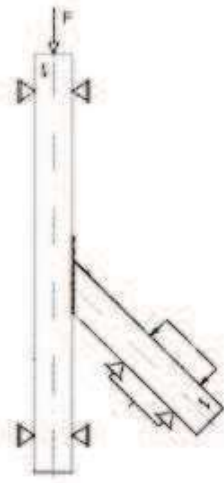
No.	Scheme	Connector types
5		KLR 1 KLR 2 KLR 3 KLR 4 KLR 5 KLR 6

Figure 65 Scheme 5


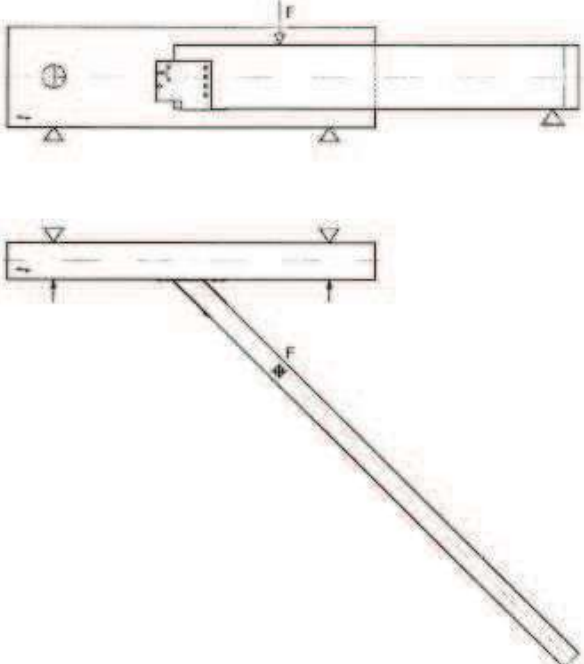
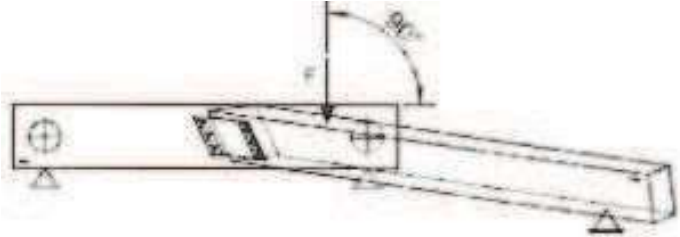
No.	Scheme	Connector types
6		WBC 80 WBC 92 WBC 100 WBC 120 WBC 137

Figure 66 Scheme 6

No.	Scheme	Connector types
7		<p>WBU 45  R45-105; L45-105  R50-105; L50-105  R60-120; L60-120</p>

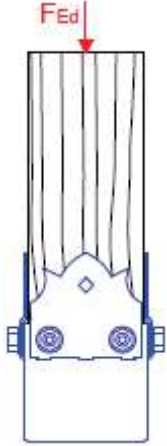
**Figure 67** Scheme 7

No.	Scheme	Connector types
8		<p>LU 25  R80; L80  R120; L120</p>

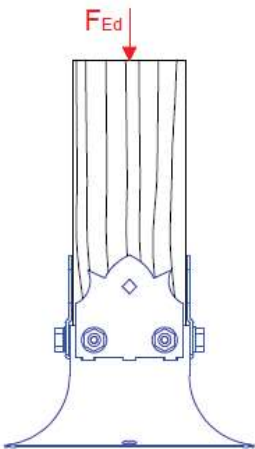
**Figure 68** Scheme 8



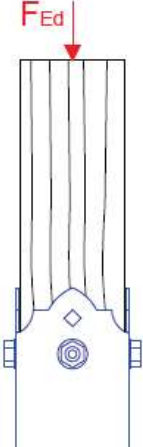
**CALCULATIONS ACCORDING TO STATIC DIAGRAMS**  
(for selected elements)

No.	Scheme	Connector types
9		<p align="center">SDP 90 A SDP 100 A SDP 120 A</p>

**Figure 69** Scheme 9

No.	Scheme	Connector types
10		<p align="center">SDP 90 B SDP 100 B SDP 120 B</p>

**Figure 70** Scheme 10

No.	Scheme	Connector types
11		<p align="center">SDSP 70 A</p>

**Figure 71** Scheme 11

No.	Scheme	Connector types
12		SDSP 70 B

Figure 72 Scheme 12

No.	Scheme	Connector types
13		KPS 1 KPS 2 KPS 3 KPS 4

Figure 73 Scheme 13

No.	Scheme	Connector types
14		PS 60 PS 70 PS 80 PS 90 PS 100 PS 120 PS 140

Figure 74 Scheme 14

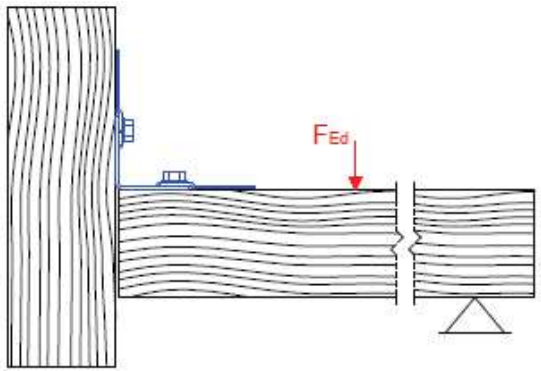
No.	Scheme	Connector types
15		SDKL 1 pull out

Figure 75 Scheme 15

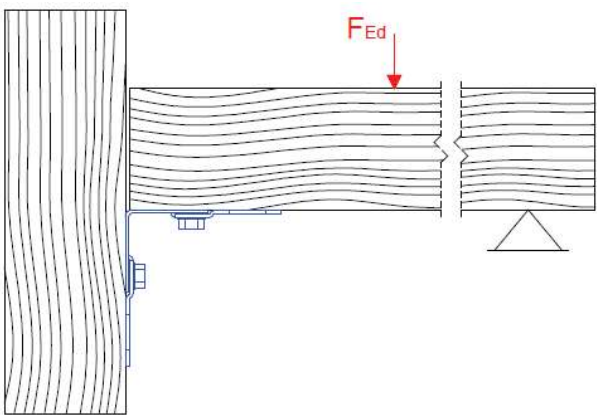
No.	Scheme	Connector types
16		SDKL 1 pressure

Figure 76 Scheme 16

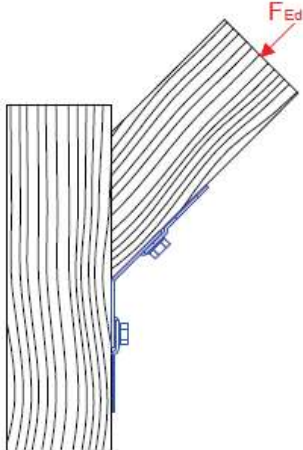
No.	Scheme	Connector types
17		SDKLR 1

Figure 77 Scheme 17

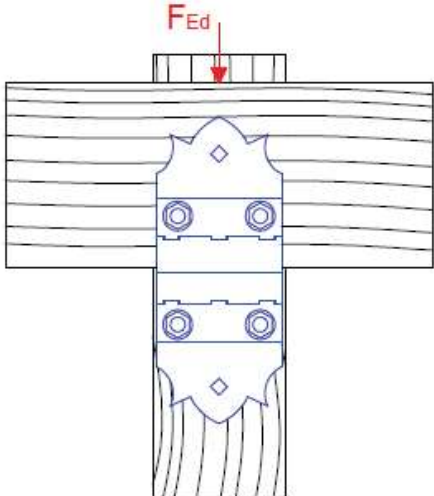
No.	Scheme	Connector types
18		SDLZ 1

Figure 78 Scheme 18

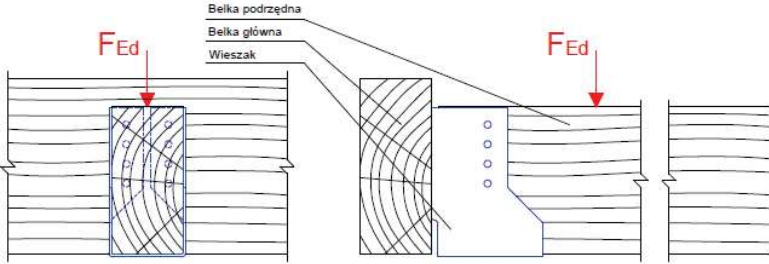
No.	Scheme	Connector types
19	 <p data-bbox="534 981 638 1048">         Bełka podrzędna          Bełka główna          Wieszak       </p>	SDSWBZ 10 SDSWBZ 11 SDSWBZ 14 SDSWBZ 21 SDSWBZ 26 SDSWBZ 30

Figure 79 Scheme 19

## ANNEX 3

### THE CHARACTERISTIC LOAD-CARRYING CAPACITIES OF CONNECTORS

**Table 37**

Type group	Type	Timber Moisture [%]	Density $\rho_{mean, 12\%}$ [ $\text{kg}\cdot\text{m}^{-3}$ ]	$P_{max, mean}$ [kN]	$P_{max, k}$ [kN]	Note No.
KP	KP 7	16.9	428.2	18.34	12.5	1
	KP 8	23.0	411.7	20.62	12.9	1
KPL	KPL 5	15.2	421.2	8.09	6.8	2
	KPL 6	12.9	422.8	9.49	6.2	2
	KPL 11	14.9	452.1	18.43	13.0	2
	KPL 21	15.6	472.7	21.23	17.1	2
KPK	KPK 4	14.3	416.8	15.85	12.7	2
	KPK 11	17.7	460.8	13.00	10.4	2
	KPK 12	14.3	460.9	17.32	13.5	2
	KPK 13	13.4	398.2	22.13	16.7	2
	KPK 21	12.3	468.5	13.53	10.8	2
	KPK 22	11.3	407.5	13.14	10.6	2
	KPK 23	11.3	460.9	12.79	9.0	2
	KPK 31	13.6	436.6	12.44	9.3	3
	KPK 32	12.2	424.8	12.62	10.5	3
KPK 33	15.4	415.4	13.66	10.5	3	
KLR	KLR 1	13.8	422.2	5.71	4.2	2
	KLR 2	15.5	429.7	10.95	7.9	2
	KLR 3	15.5	407.1	10.59	8.3	2
	KLR 4	15.7	468.1	6.35	5.1	2
	KLR 5	15.3	410.8	15.41	13.6	2
	KLR 6	16.0	497.6	9.98	7.2	2
KR	KR 1	13.4	438.8	6.74	5.1	2
	KR 2	14.6	396.2	12.29	6.7	2
	KR 3	14.7	408.7	7.53	6.3	2
WBC	WBC 80	14.7	423.2	42.06	34.9	2
	WBC 92	16.8	424.0	42.79	36.1	2
	WBC 100	14.9	423.6	42.71	26.8	2
	WBC 120	16.7	414.3	47.22	29.2	2
	WBC 137	14.9	428.4	52.44	42.1	2
WBU	WBU 45 R45-105	15.6	385.4	16.96	11.0	2
	WBU 45 R50-105	14.5	387.0	16.43	12.4	2
	WBU 45 R60-120	14.9	423.8	21.47	16.5	2
KRD	KRD 5	16.1	453.8	9.65	6.1	2
	KRD 6	16.1	430.8	8.74	6.1	2
LU	LU 25 R80	14.7	436.5	9.07	6.1	2
	LU 25 R120	14.6	414.5	14.76	12.3	2

Notes:

1 Given forces are per one connector (one angle bracket), the test connections consisted of two connectors, forces for the complete connections are twice as high

2 One connector

3 The forces are given for the complete connection consisting of two connectors, hence force per one connector (one angle bracket) is half of the given value

## THE CHARACTERISTIC LOAD-CARRYING CAPACITIES OF JOINTS (LOADING)

**Table 38**

Type group	Type	Timber Moisture [%]	Density $\rho_{mean, 12\%}$ [kg·m <sup>-3</sup> ]	$P_{max, mean}$ [kN]	$P_{max, k}$ [kN]	Note No.
ŁB	ŁB 1	12.0	400.1	13.41	9.9	1
	ŁB 2	12.0	400.1	15.27	10.4	1
	ŁB 4	12.0	400.1	12.73	9.4	1
NT	NT 25			25.26	15.7	2
	NT 40			37.14	32.8	2
	NT 60			67.62	59.8	2
KKB	KKB 1	12.0	400.0	81.14	57.6	3

Notes:

1 Given forces are for one connector, the test connections consisted of two connectors, hence the force for the complete connection is twice the given

2 One connector loaded in tension

3 Given forces are for the complete connection, the test connections consisted of two connectors, hence force for one connector is half of the given

## THE CHARACTERISTIC LOAD-CARRYING CAPACITIES OF JOINTS (CALCULATIONS)

**Table 39**

Type of connector	Load	Bearing Capacity [kN]		Method of determination	Document No.
		Timber	Steel		
SDLZ 1	shear	3.6		calculation	KAO-O-SOD-13
SDKLR 1	oblique	3.3		calculation	KAO-O-SOD-12
SDKL 1	pull out		1.1	calculation	KAO-O-SOD-10
	pressure	3.3		calculation	KAO-O-SOD-11
SDSP 70 A	pressure	34.8		calculation	KAO-O-SOD-23
SDSP 70 B	pressure	108.6		calculation	KAO-O-SOD-24
SDP 90 A	pressure	39.6		calculation	KAO-O-SOD-15
SDP 90 B	pressure	180.6		calculation	KAO-O-SOD-17
SDP 100 A	pressure	39.6		calculation	KAO-O-SOD-15
SDP 100 B	pressure	220.5		calculation	KAO-O-SOD-17
SDP 120 A	pressure	39.6		calculation	KAO-O-SOD-15
SDP 120 B	pressure	312.9		calculation	KAO-O-SOD-17
SDSKW 2	pressure	3.3		testing	KAO-O-SOD-21
SDSKW 8	pressure	3.5		testing	KAO-O-SOD-22
SDSKP 1	pressure	17.8		testing	KAO-O-SOD-21
SDSKP 5	pressure	10.9		testing	KAO-O-SOD-21
SDSKM 7	pressure	5.8		testing	KAO-O-SOD-21
SDSWBZ 10	pressure	9.6		calculation	KAO-O-SOD-18
SDSWBZ 11	pressure	12.3		calculation	KAO-O-SOD-19
SDSWBZ 14	pressure	9.3		calculation	KAO-O-SOD-20
SDSWBZ 21	pressure	17.2		testing	KAO-O-SOD-21
SDSWBZ 26	pressure	17.2		testing	KAO-O-SOD-21
SDSWBZ 30	pressure	22.4		testing	KAO-O-SOD-21

## THE CHARACTERISTIC LOAD-CARRYING CAPACITIES OF JOINTS (CALCULATIONS)

**Table 40**

Type of connector	Characteristic bearing capacity [kN]		Document No.
	Timber		
PS 60	4.1		BPS-0001/13
PS 70	4.3		BPS-0002/13
PS 80	6.9		BPS-0003/13
PS 90	6.2		BPS-0004/13
PS 100	6.7		BPS-0005/13
PS 120	8.2		BPS-0006/13
PS 140	7.5		BPS-0007/13
KPS 1	16.3		KE1-0009/14
KPS 2	18.7		KE1-0010/14
KPS 3	12.6		KE1-0011/14
KPS 4	11.6		KE1-0012/14

**Table 41** Overview of bearing capacities of connector type PS [kN]

Type of connector	Bearing capacity $N_{Rd,V}$ [kN] (calculation)		Bearing capacity $N_{Rd,H1}$ [kN] (calculation)		Bearing capacity $N_{Rd,H2}$ [kN] (testing)
	Bearing capacity of timber	Bearing capacity of steel	Bearing capacity of timber	Bearing capacity of steel	
PS 60	61.7	51.7	12.2	6.9	4.7
PS 70	86.6	51.7	12.2	6.9	4.4
PS 80	99.2	57.3	12.2	9.6	7.7
PS 90	111.8	57.3	12.2	9.6	6.8
PS 100	124.4	57.3	12.2	9.6	7
PS 120	149.6	57.3	12.2	9.6	9.1
PS 140	174.8	57.3	12.2	9.6	7.8

$N_{Rd,V}$  - Vertical load force,  $N_{Rd,H1}$  - Horizontal load force,  $N_{Rd,H2}$  - Vertical load force parallel to the side of base  
Document No.: KAO-L-PS-01

For combinations of loads ( $F_{Ed,V}$ ,  $F_{Ed,H1}$ ,  $F_{Ed,H2}$ ) a linear summation of the utilization ratios may be used. This method may be applied by using a following criteria:

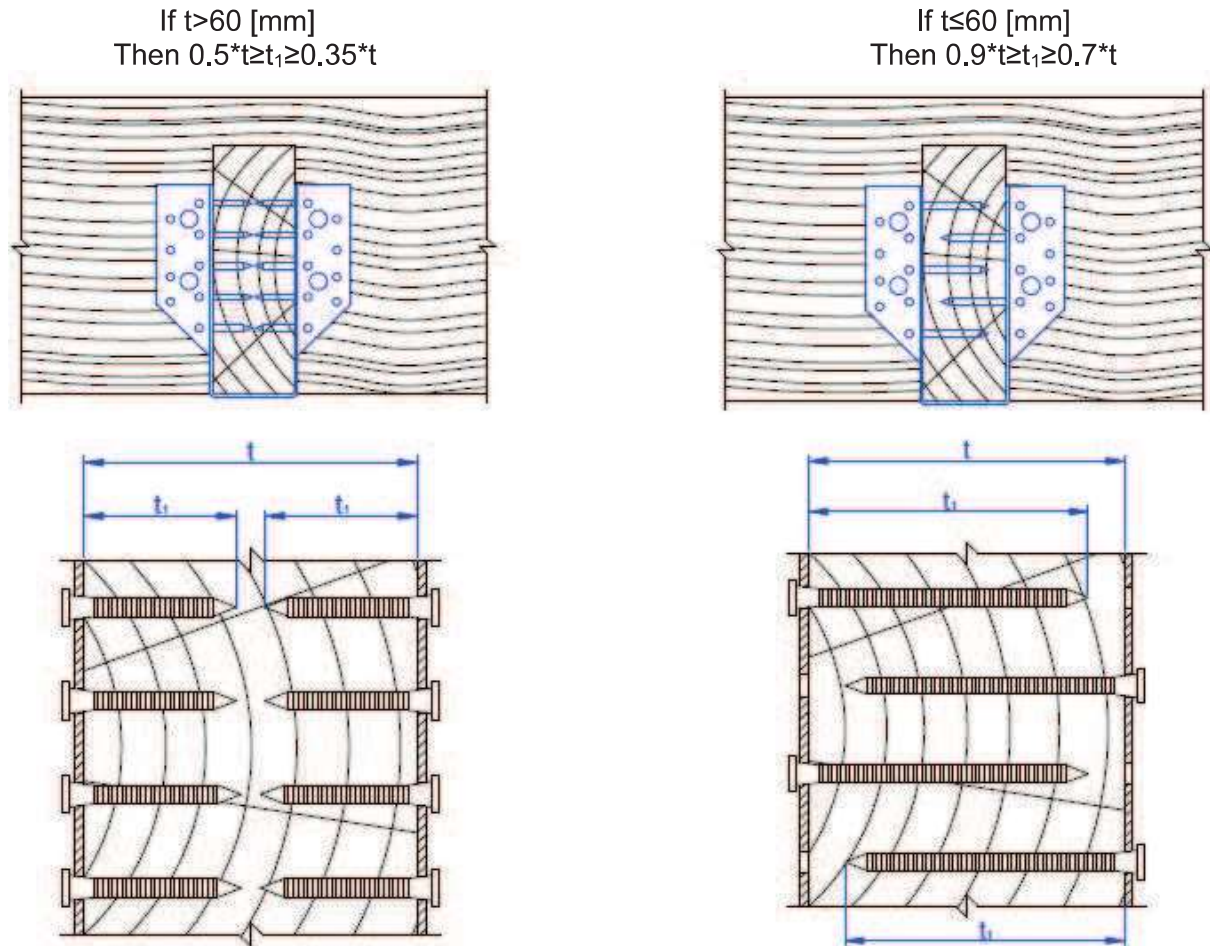
$$\frac{F_{Ed,V}}{N_{Rd,V}} + \frac{F_{Ed,H1}}{N_{Rd,H1}} + \frac{F_{Ed,H2}}{N_{Rd,H2}} \leq 1$$



## ANNEX 4

### NAILING PATTERNS

It is always necessary to put nails in the black marked holes. This is the only one proper pattern because too many or too long nails can weaken the wood, it's quite close to edge (rule is stated below).



**Figure 80** Rule for placement nails

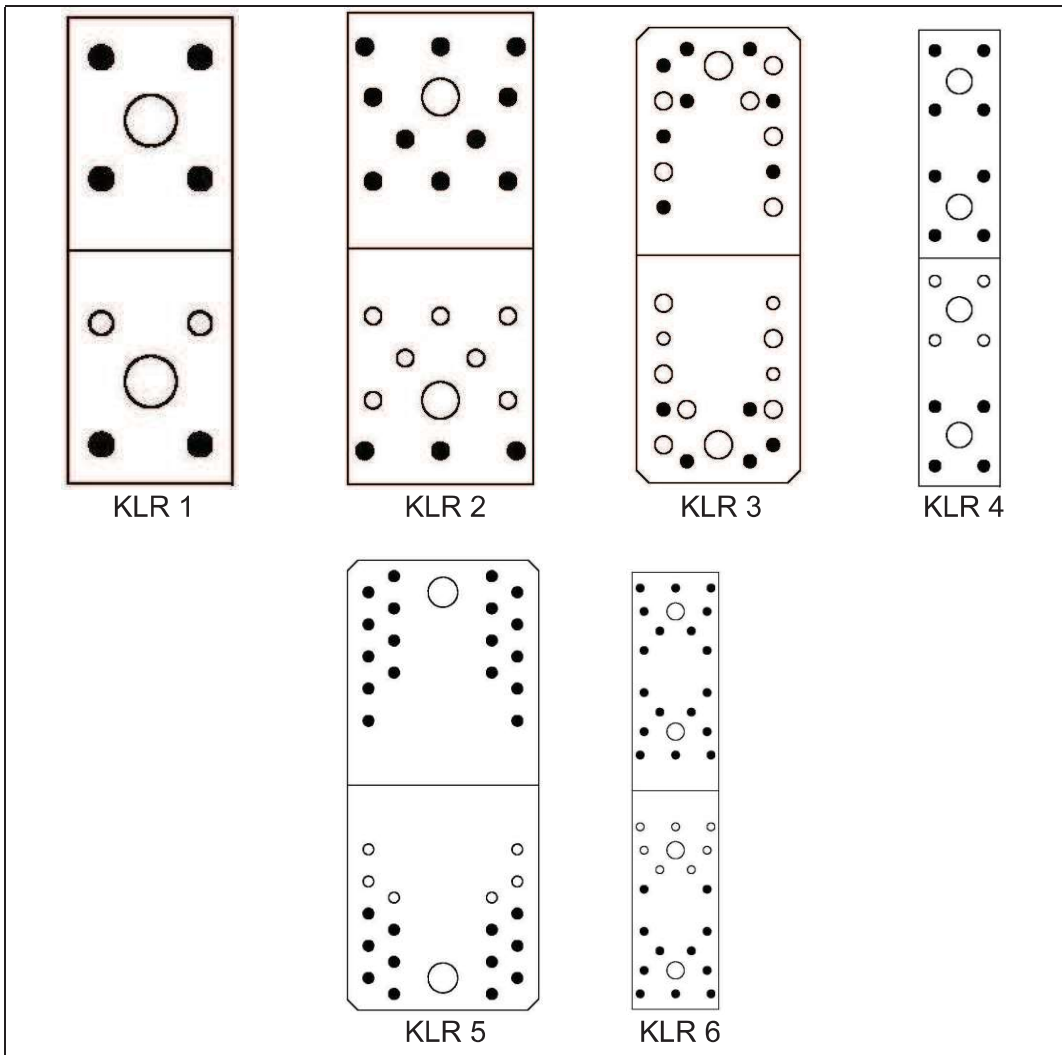


Figure 81 Type KLR

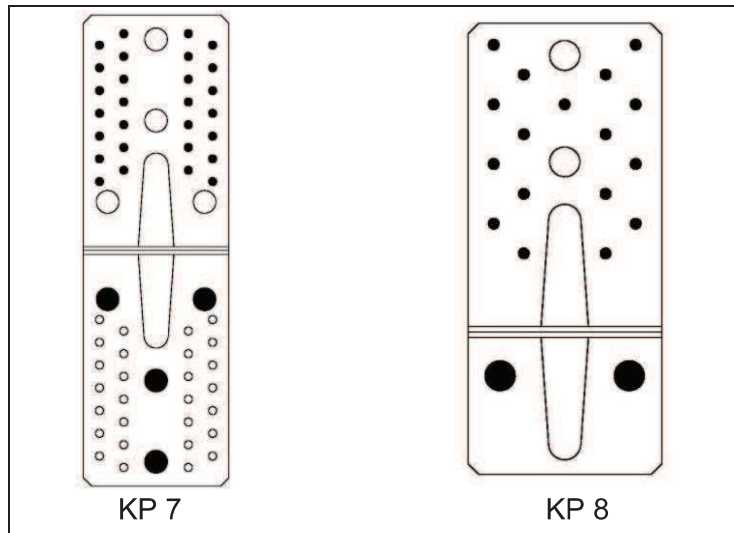


Figure 82 Type KP

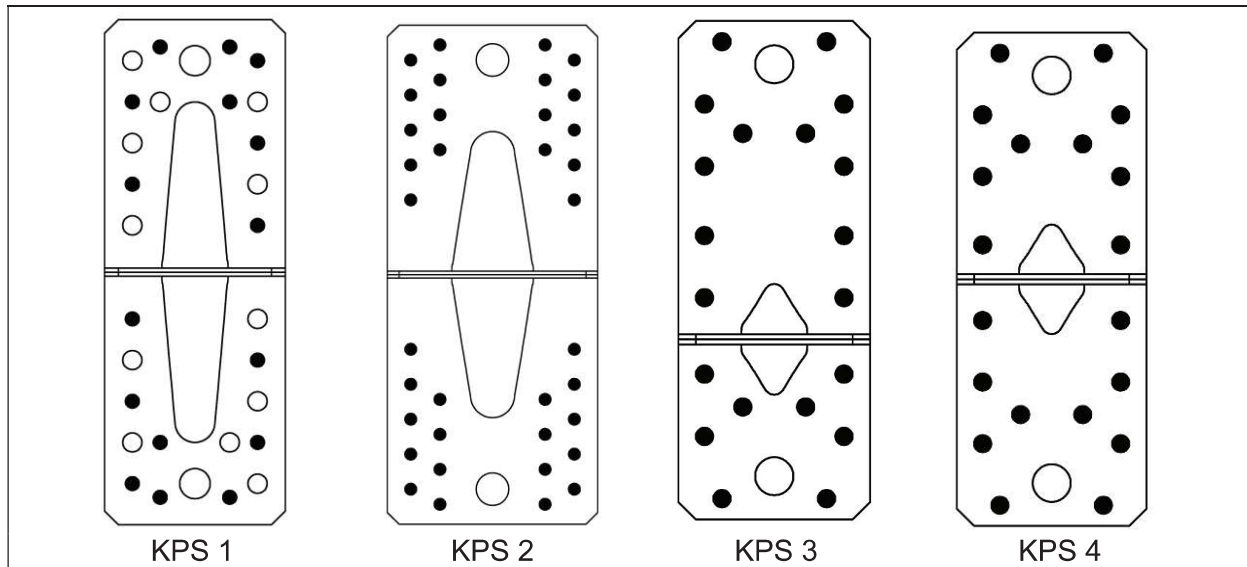


Figure 83 Type KPS

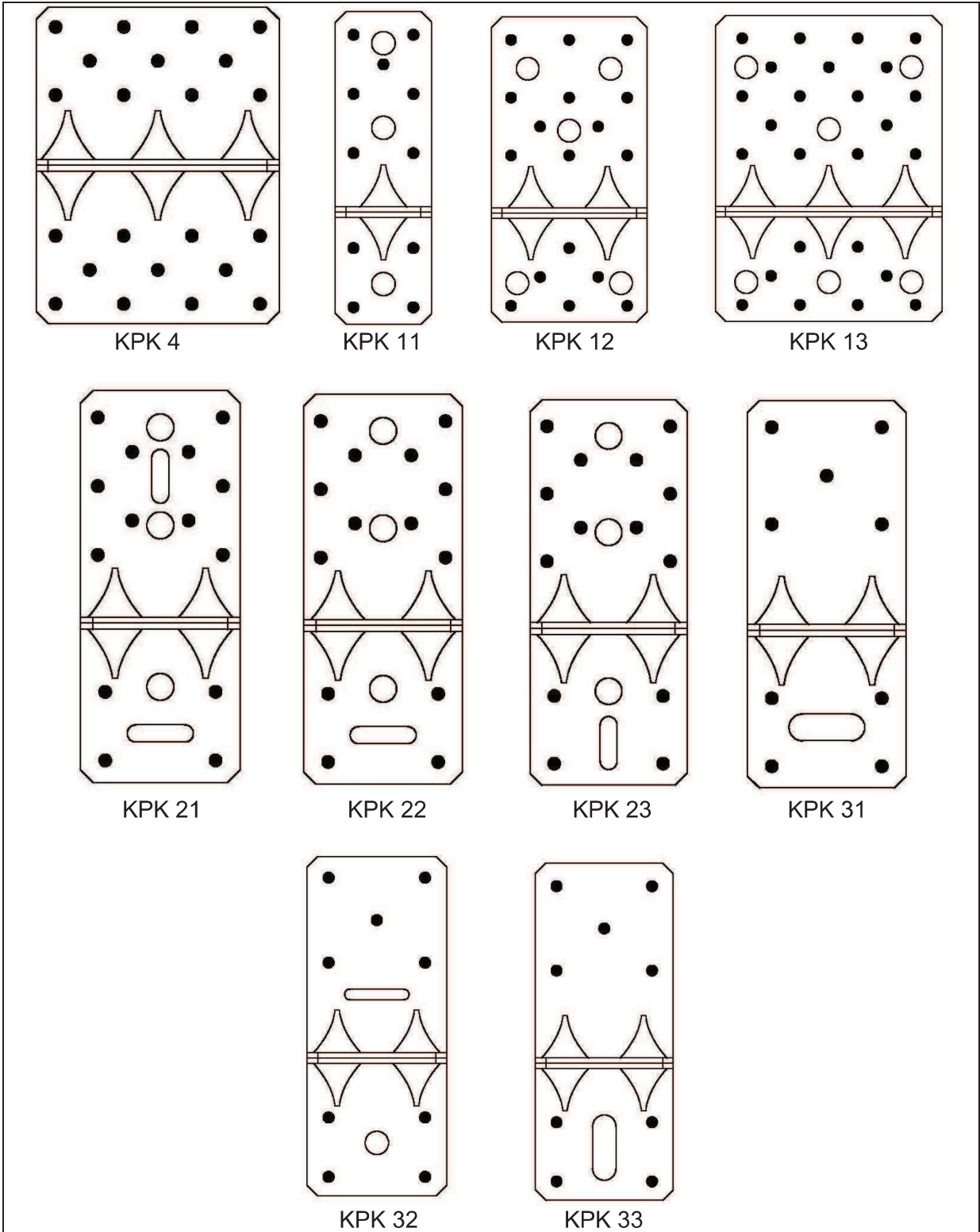


Figure 84 Type KPK

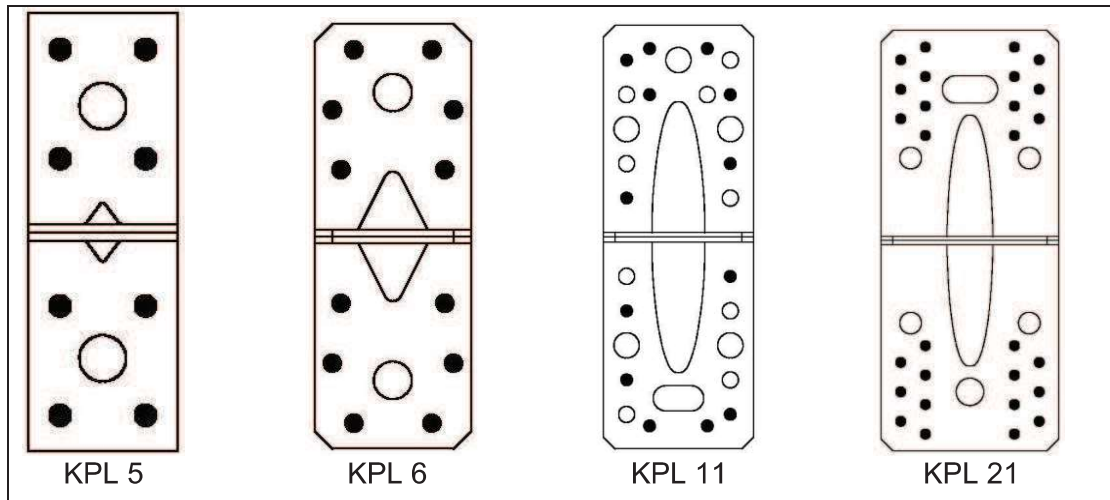


Figure 85 Type KPL

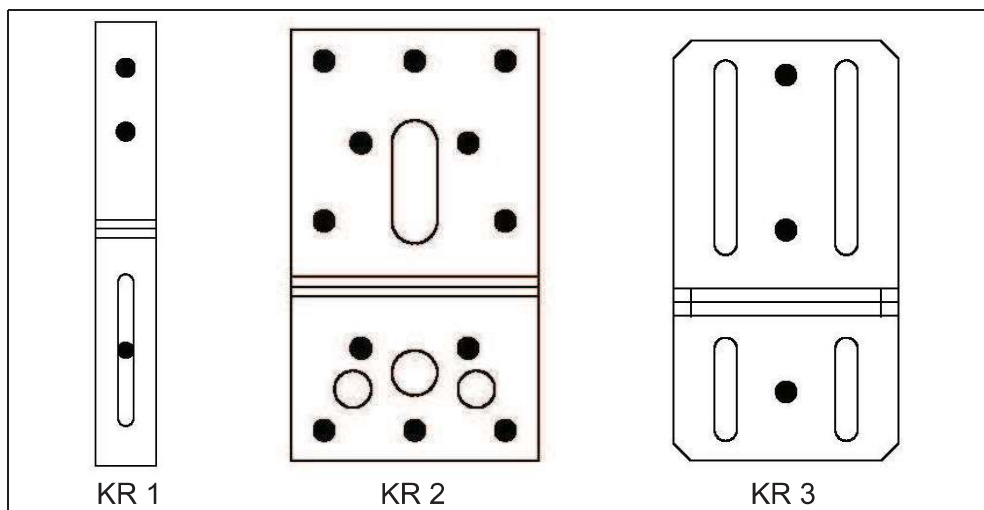


Figure 86 Type KR

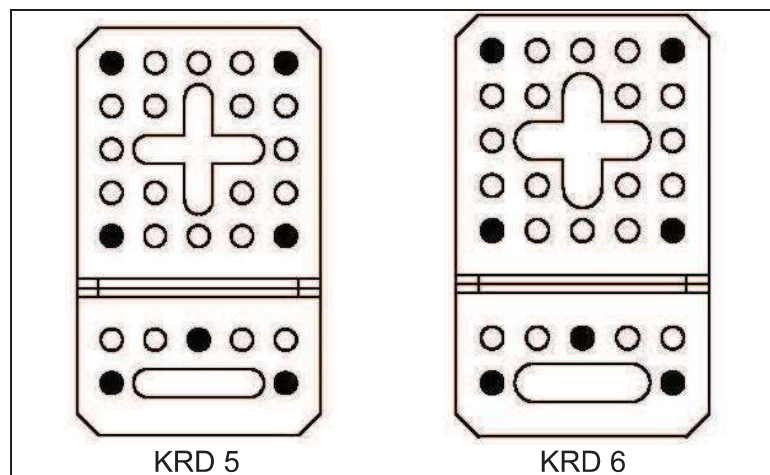


Figure 87 Type KRD

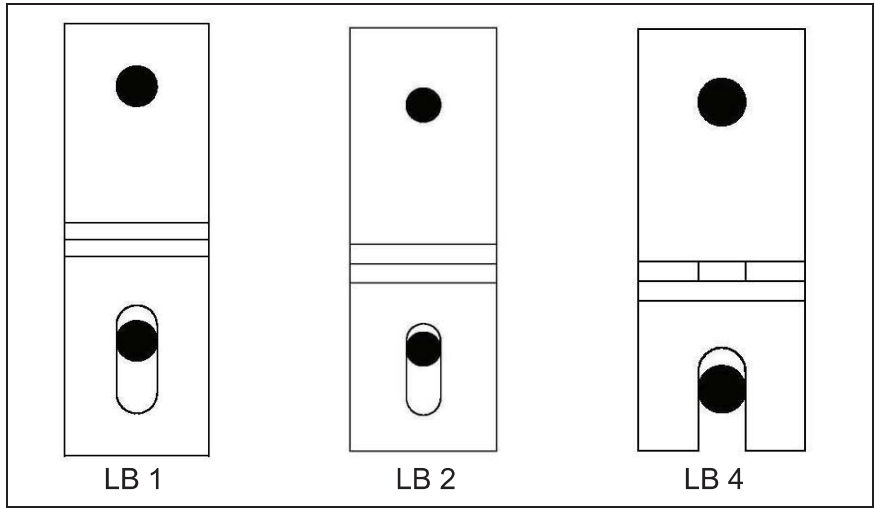


Figure 88 Type LB

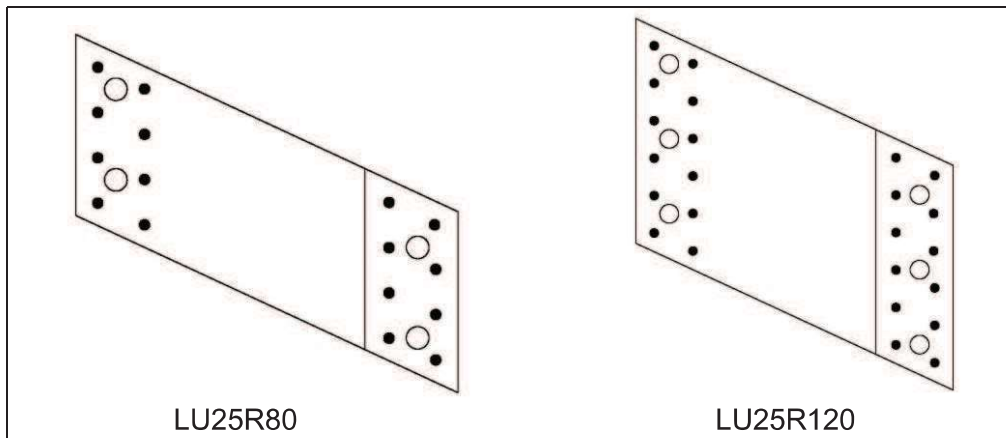


Figure 89 Type LU

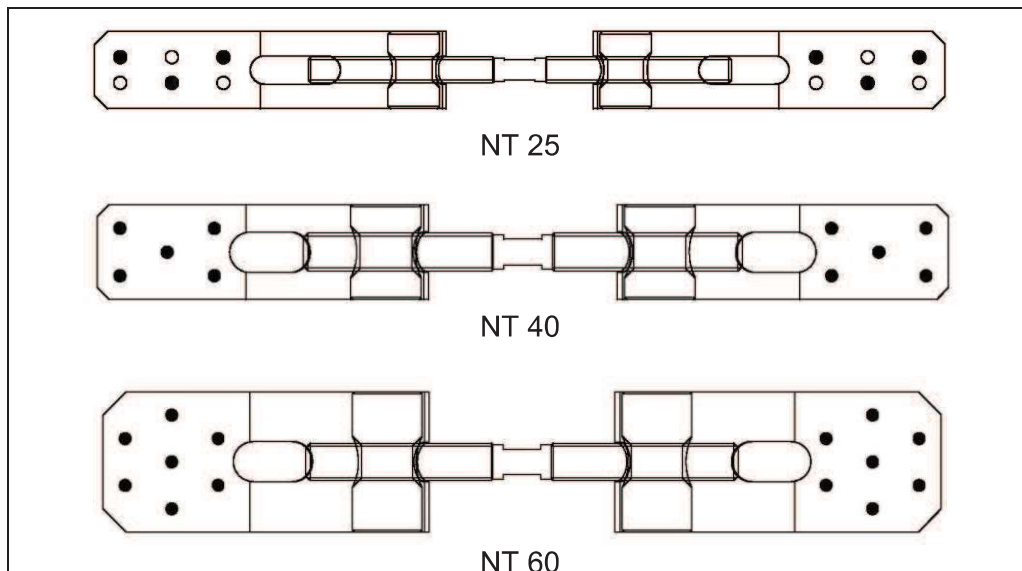
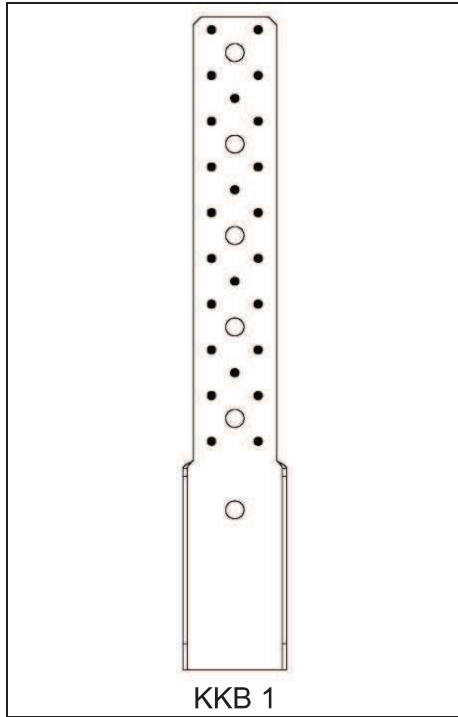
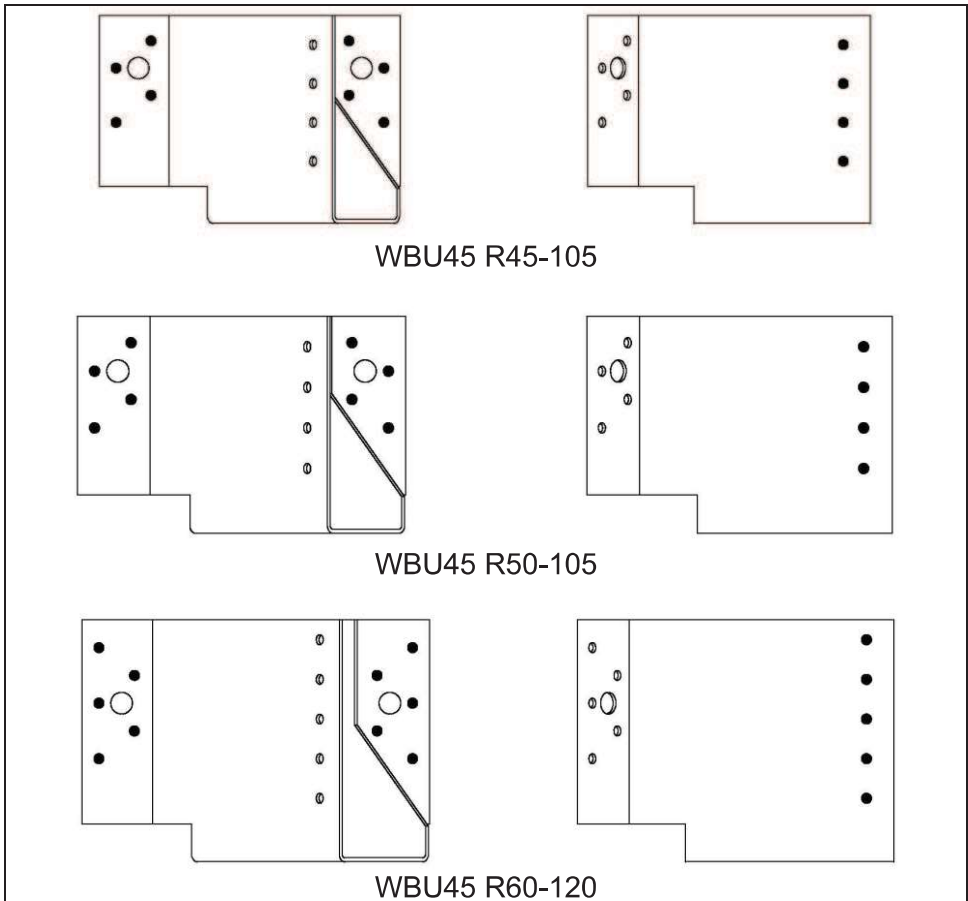


Figure 90 Type NT

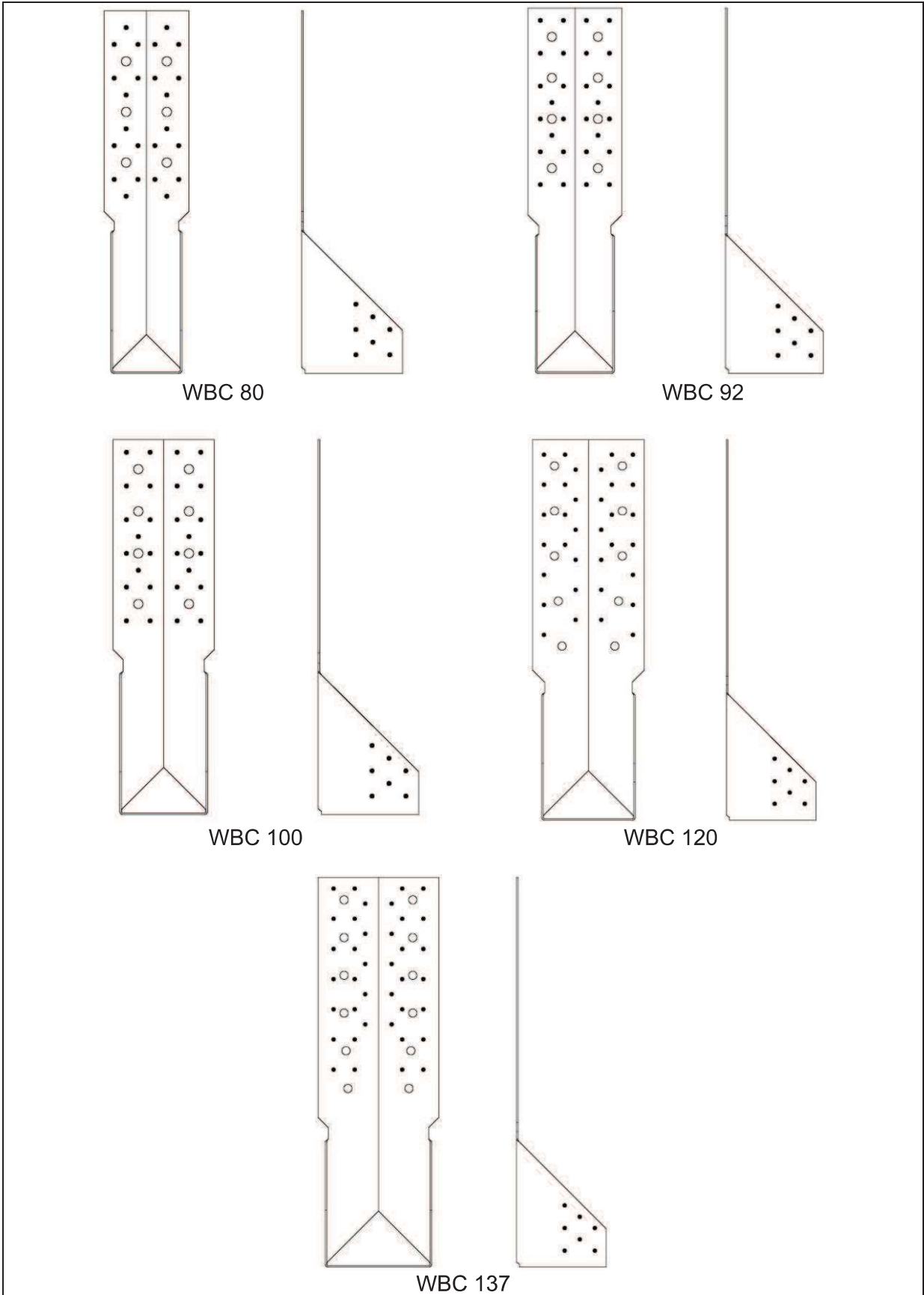


**Figure 91** Type KKB



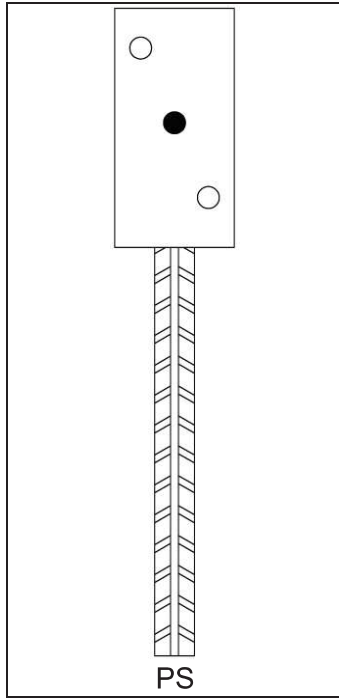
**Figure 92** Type WBU



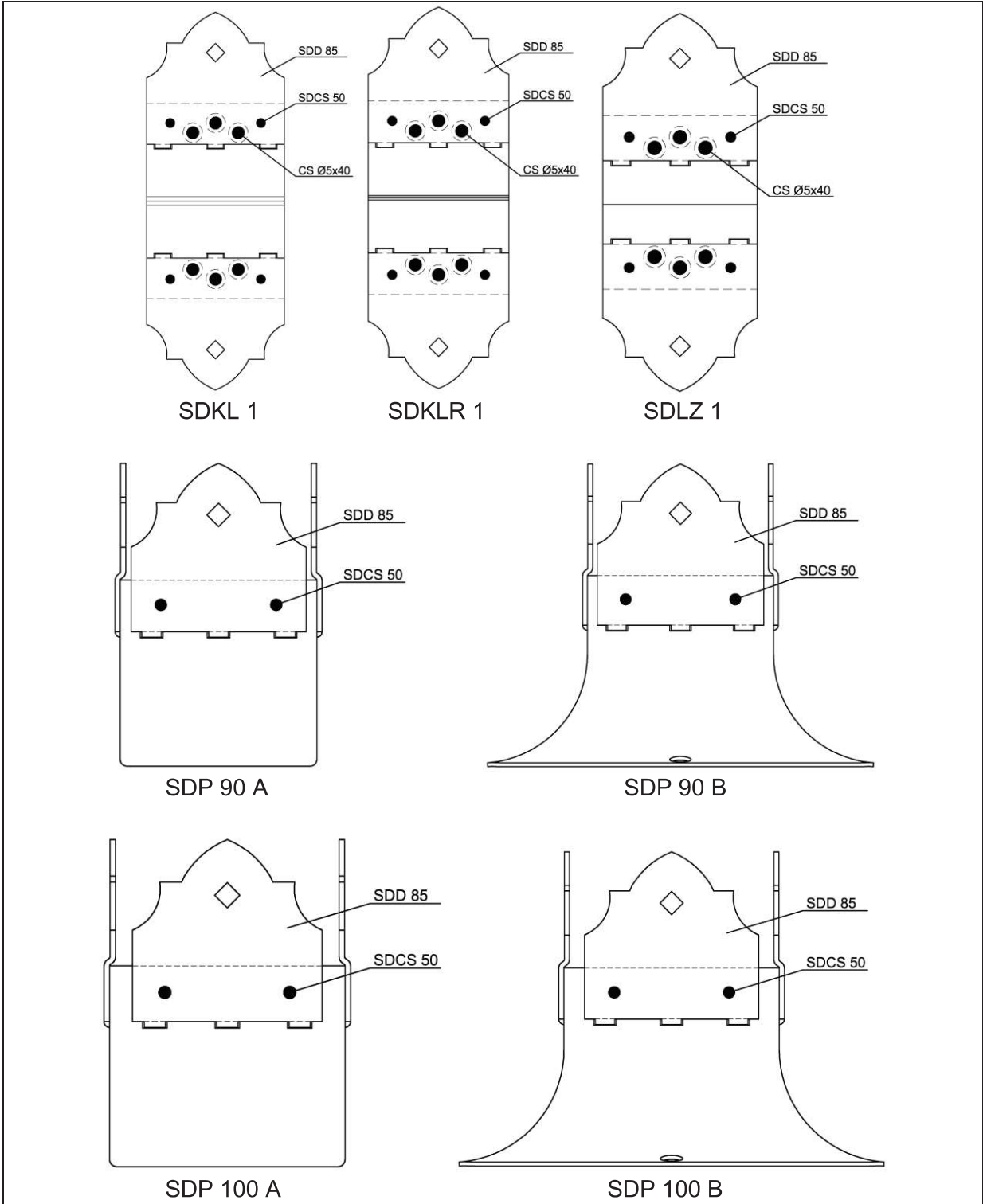


**Figure 93** Type WBC





**Figure 94 Type PS**



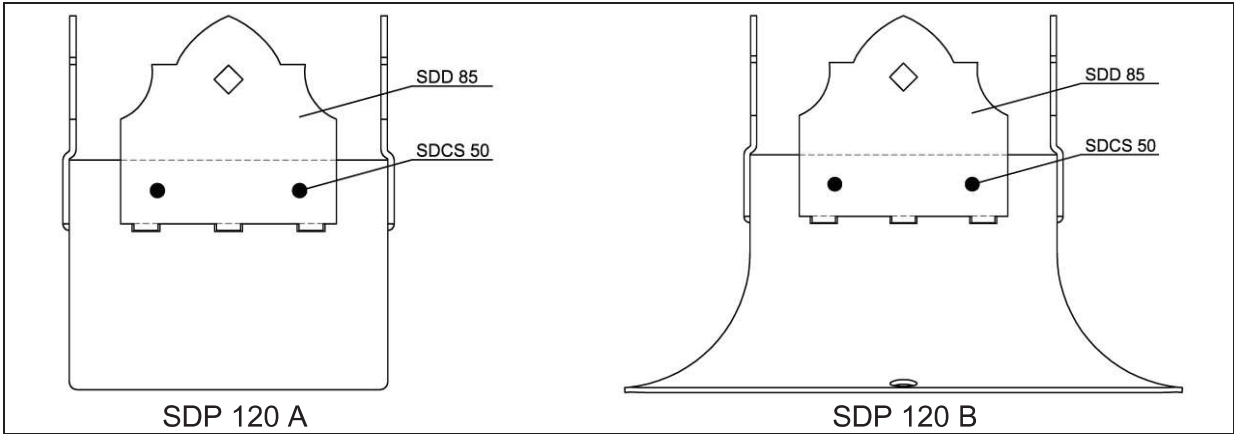
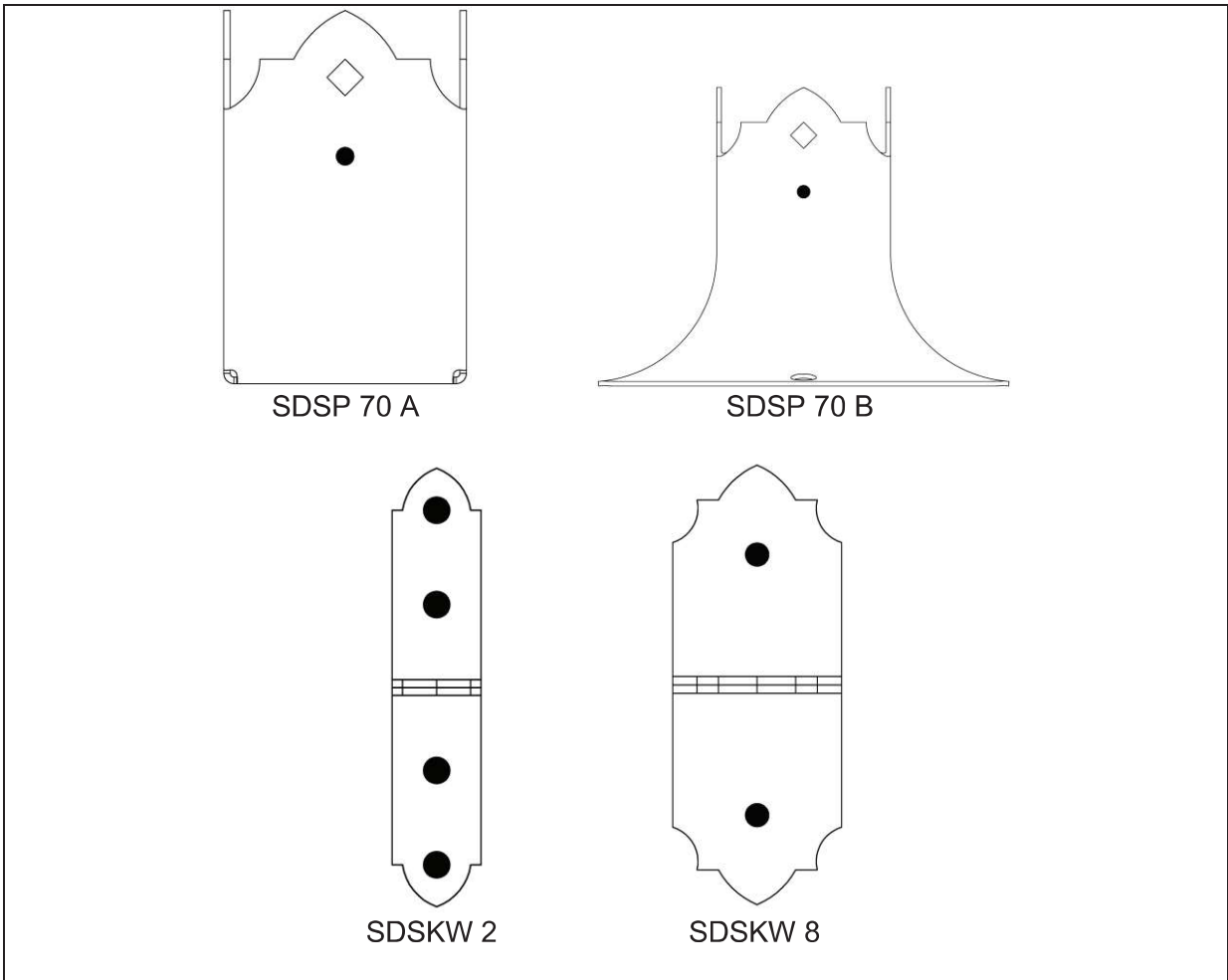
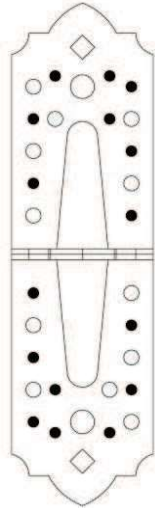
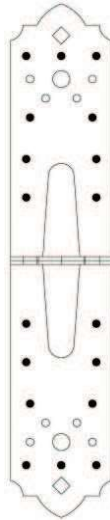


Figure 95 Type SD

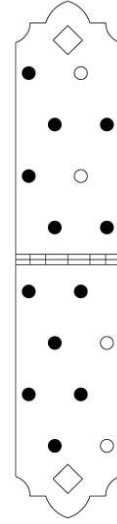




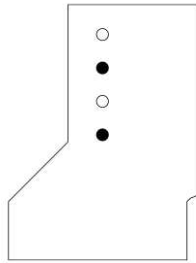
SDSKP 1



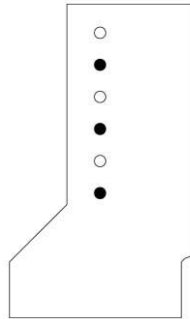
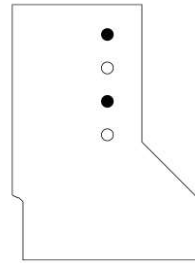
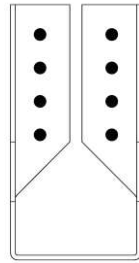
SDSKP 5



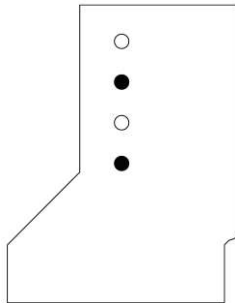
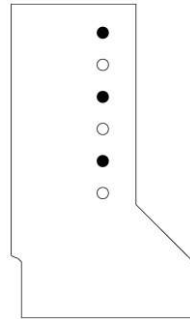
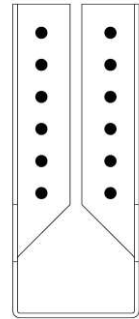
SDSKM 7



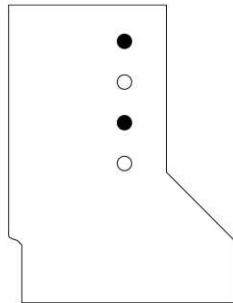
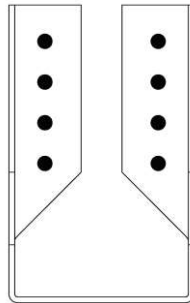
SDSWBZ 10

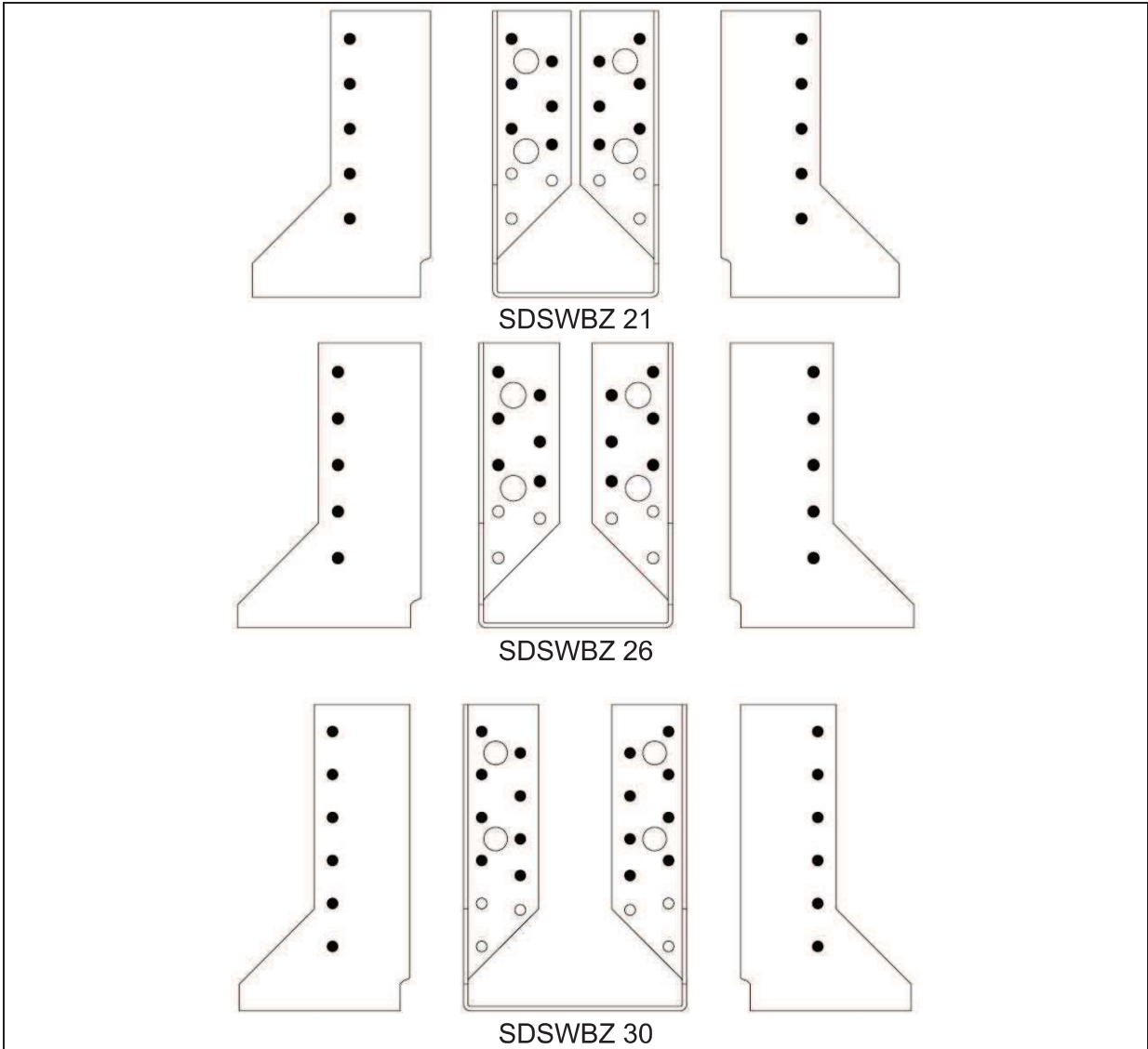


SDSWBZ 11



SDSWBZ 14





**Figure 96** Type SDS

## ANNEX 5

### SPECIFICATION OF CONNECTION ELEMENTS

Table 42

Detail	Dowel type connectors	Connectors/Detail [pc.]	Connectors/Connection [pc.]
KLR 1	ANCHOR $\emptyset$ 4x50	6	6
KLR 2	ANCHOR $\emptyset$ 4x50	13	13
KLR 3	ANCHOR $\emptyset$ 4x50	13	13
KLR 4	ANCHOR $\emptyset$ 4x50	12	12
KLR 5	ANCHOR $\emptyset$ 4x50	30	30
KLR 6	ANCHOR $\emptyset$ 4x50	29	29
KP 7	ANCHOR $\emptyset$ 4x50 / DIN 571 $\emptyset$ 12x100	28 / 4	56 / 8
KP 8	ANCHOR $\emptyset$ 4x50 / DIN 571 $\emptyset$ 12x100	17 / 2	34 / 4
KPK 4	ANCHOR $\emptyset$ 4x50	22	22
KPK 11	ANCHOR $\emptyset$ 4x50	11	11
KPK 12	ANCHOR $\emptyset$ 4x50	17	17
KPK 13	ANCHOR $\emptyset$ 4x50	25	25
KPK 21	ANCHOR $\emptyset$ 4x50	14	14
KPK 22	ANCHOR $\emptyset$ 4x50	14	14
KPK 23	ANCHOR $\emptyset$ 4x50	14	14
KPK 31	ANCHOR $\emptyset$ 4x50	9	18
KPK 32	ANCHOR $\emptyset$ 4x50	9	18
KPK 33	ANCHOR $\emptyset$ 4x50	9	18
KPL 5	ANCHOR $\emptyset$ 4x50	8	8
KPL 6	ANCHOR $\emptyset$ 4x50	12	12
KPL 11	ANCHOR $\emptyset$ 4x50	13	13
KPL 21	ANCHOR $\emptyset$ 4x50	28	28
KR 1	ANCHOR $\emptyset$ 4x50	3	3
KR 2	ANCHOR $\emptyset$ 4x50	12	12
KP 3	ANCHOR $\emptyset$ 4x50	3	3
KRD 5	ANCHOR $\emptyset$ 4x50	7	7
KRD 6	ANCHOR $\emptyset$ 4x50	7	7
SDLZ 1	SDCS 50 / CS $\emptyset$ 5x40	4 / 6	4 / 6
SDKLR 1	SDCS 50 / CS $\emptyset$ 5x40	4 / 6	4 / 6
SDKL 1	SDCS 50 / CS $\emptyset$ 5x40	4 / 6	4 / 6
SDSP 70 A	SDCS 50	4	4
SDSP 70 B	SDCS 50	4	4
SDP 90 A	SDCS 50	8	8
SDP 90 B	SDCS 50	8	8
SDP 100 A	SDCS 50	8	8
SDP 100 B	SDCS 50	8	8
SDP 120 A	SDCS 50	8	8
SDP 120 B	SDCS 50	8	8

Detail	Dowel type connectors	Connectors/Detail [pc.]	Connectors/Connection [pc.]
SDSKW 2	ANCHOR ø 4x50	4	8
SDSKW 8	SDCS 50	2	4
SDSKP 1	ANCHOR ø 4x50	16	32
SDSKP 5	ANCHOR ø 4x50	18	36
SDSKM 7	ANCHOR ø 4x50	12	24
SDSWBZ 10	ANCHOR ø 4x50 / ANCHOR ø 4x40	8 / 4	8 / 4
SDSWBZ 11	ANCHOR ø 4x50 / ANCHOR ø 4x40	12 / 6	12 / 6
SDSWBZ 14	ANCHOR ø 4x50 / ANCHOR ø 4x40	8 / 4	8 / 4
SDSWBZ 21	ANCHOR ø 4x50 / ANCHOR ø 4x40	12 / 10	12 / 10
SDSWBZ 26	ANCHOR ø 4x50 / ANCHOR ø 4x40	12 / 10	12 / 10
SDSWBZ 30	ANCHOR ø 4x50 / ANCHOR ø 4x40	16 / 12	16 / 12
PS 60	ISO 4014 M10x80-5.8	1	1
PS 70	ISO 4014 M10x90-5.8	1	1
PS 80	ISO 4014 M10x100-5.8	1	1
PS 90	ISO 4014 M10x110-5.8	1	1
PS 100	ISO 4014 M10x120-5.8	1	1
PS 120	ISO 4014 M10x140-5.8	1	1
PS 140	ISO 4014 M10x160-5.8	1	1
LU25 R80 (L80)	ANCHOR ø 4x50	16	16
LU25 R120 (L120)	ANCHOR ø 4x50	24	24
WBC 80	ANCHOR ø 4x50 / ANCHOR ø 4x40	24 / 14	24 / 14
WBC 92	ANCHOR ø 4x50 / ANCHOR ø 4x40	28 / 14	28 / 14
WBC 100	ANCHOR ø 4x50 / ANCHOR ø 4x40	28 / 14	28 / 14
WBC 120	ANCHOR ø 4x50 / ANCHOR ø 4x40	34 / 14	34 / 14
WBC 137	ANCHOR ø 4x50 / ANCHOR ø 4x40	38 / 14	38 / 14
WBU45 R45-105 (L45-105)	ANCHOR ø 4x50 / ANCHOR ø 4x40	8 / 4	8 / 4
WBU45 R50-105 (L50-105)	ANCHOR ø 4x50 / ANCHOR ø 4x40	8 / 4	8 / 4
WBU45 R60-120 (L60-120)	ANCHOR ø 4x50 / ANCHOR ø 4x40	10 / 5	10 / 5
KKB 1	ANCHOR ø 4x50 / ISO 4014 M16x160-5.8	24 / 1	48 / 2
LB 1	ISO 4014 M12x120-5.8 / ISO 4014 M12x90-5.8	1 / 1	1 / 2
LB 2	ISO 4014 M12x120-5.8 / ISO 4014 M12x90-5.8	1 / 1	1 / 2
LB 4	ISO 4014 M12x120-5.8 / ISO 4014 M12x90-5.8	1 / 1	1 / 2
NT 25	ISO 4017 M5x16-8.8	6	6
NT 40	ISO 4017 M5x16-8.8	10	10
NT 60	ISO 4017 M5x16-8.8	14	14
KPS 1	ANCHOR ø 4x50	16	32
KPS 2	ANCHOR ø 4x50	36	72
KPS 3	ANCHOR ø 4x50	20	40

<b>Detail</b>	<b>Dowel type connectors</b>	<b>Connectors/Detail [pc.]</b>	<b>Connectors/Connection [pc.]</b>
KPS 4	ANCHOR $\emptyset$ 4x50	20	40



## ANNEX 6

### REFERENCE DOCUMENTS

- [1] Guideline for European Technical Approval of Three-dimensional nailing plates ETAG 015 (edition November 2012)
- [2] Declaration about dangerous substances issued by DOMAX sp. z o.o.
- [3] EN 26891:1991 Timber structures – Joints made with mechanical fasteners – General principles for the determination of strength and deformation characteristics
- [4] EN ISO 8970:2010 Timber structures – Testing of joints made with mechanical fasteners – Requirements for wood density
- [5] EN 384+A1:2019 Structural timber – Determination of characteristic values of mechanical properties and density
- [6] EN 13183-2:2002 Moisture content of a piece of sawn timber - Part 2: Estimation by electrical resistance method
- [7] EN 1309-1:1997 Round and sawn timber - Method of measurement of dimensions - Part 1: Sawn timber
- [8] EN 14358:2006 Timber structures – Calculation and verification of characteristic values
- [9] EOTA TR 016 “*Method of testing Three-Dimensional Nailing Plates with examples*”, version February 2002

**4 Assessment and verification of constancy of performance (hereinafter AVCP) system applied, with reference to its legal base**

According to the decision 1997/638/EC<sup>1</sup>, of the European Commission the system(s) of assessment and verification of constancy of performance (see Annex V to Regulation (EU) No 305/2011 and Commission delegated Regulation (EU) No 568/2014) given in the following table applies:

Product(s)	Intended use(s)	Level(s) or class(es)	Attestation of conformity system(s)
Shear plates, toothed-plate connectors, punched nail plates, nailing plates	For structural timber products		2+

**5 Technical details necessary for the implementation of the AVCP system, as provided for in the applicable EAD**

Issued in Prague on 28.04.2020

By  
Mária Schaan  
Head of the TAB



Annexes:

- Annex 1 Product details and definitions
- Annex 2 Loading and calculations according to static diagrams
- Annex 3 The characteristic load carrying capacities of connectors
- Annex 4 Nailing patterns
- Annex 5 Specification of connection elements
- Annex 6 Reference documents

<sup>1</sup> Official Journal of the European Communities L 268/36 of 19.9.1997