



**Technický a zkušební ústav  
stavební Praha, s.p.**  
Prosecká 811/76a  
190 00 Prague  
Czech Republic  
tel.: +420 286 019 400  
W: www.tzus.cz



Member of



www.eota.eu

## European Technical Assessment

**ETA 15/0725**  
of 28/04/2020

General part

### Technical Assessment Body issuing the European Technical Assessment

Technický a zkušební ústav stavební Praha, s.p.

|   |  |
|---|--|
| <b>Trade name of the construction product</b>   | DMX®   |
| <b>Product family to which the construction product belongs</b>   | Product area: 13<br>Three-Dimensional Nailing Plates   |
| <b>Manufacturer</b>   | DOMAX Sp.z o.o.<br>Aleja Parku Krajobrazowego 109<br>84-207 Koleczkowo<br>Łężyce<br>Republic of Poland |
| <b>Manufacturing plant</b>  | Aleja Parku Krajobrazowego 109<br>84-207 Koleczkowo<br>Łężyce<br>Republic of Poland                    |
| <b>This European Technical Assessment contains</b>  | 43 pages including 6 Annexes, which form an integral part of this European Technical Assessment        |
| <b>This European Technical Assessment is issued in accordance with Regulation (EU) No 305/2011, on the basis of</b> | ETAG 015 used as European Assessment Document (EAD)  |
| <b>This version replaces</b>  | ETA 15/0725, version 01, issued on 10/03/2016  |

Translations of this European technical assessment in other languages shall fully correspond to the original issued document and should be identified as such.

Communication of this European Technical Assessment, including transmission by electronic means, shall be in full (excepted the confidential Annex(es) referred to above). However, partial reproduction may be made, with the written consent of the issuing Technical Assessment Body - Technický a zkušební ústav stavební Praha, s.p. Any partial reproduction has to be identified as such.

## 1 Technical description of the product

The three-dimensional nailing plates DMX<sup>®</sup> are one-piece, non-welded (KB, KK, KL, KM, KP, KR, KRB, KSB, KWB, KWC, WBZ) or welded (PSL, PSP, PSPO, PST, PS 84L) or multi-piece, welded (PSR, PSRT, PSRU) elements made of the cold-formed steel sheet grade DX51D according to EN 10346 with zinc coating mass of 275 g/m<sup>2</sup>, electrogalvanized steel DC01 according to EN 10131 with corrosion protection Fe/Zn 12 + powder coating 60 μm or structural steel S235 according to EN 10025-2 with zinc coating mass of 275 g/m<sup>2</sup> or with corrosion protection Fe/Zn 12 (see list below). The three-dimensional nailing plates DMX<sup>®</sup> correspond to the drawings and dimensions given in Annex 1.

**Table 1** Technical description of the product

| Type of Domax connector   | Made of | Kind of corrosion protection    |
|---------------------------|---------|---------------------------------|
| KB 4                      | S 235   | Fe/Zn 12                        |
| KK 0                      | DC01    | Fe/Zn 12 + Powder Coating 60 μm |
| KK 11                     | DX51D   | Z275                            |
| KK 12                     | DX51D   | Z275                            |
| KL 6                      | DX51D   | Z275                            |
| KM 17                     | DX51D   | Z275                            |
| KM 18                     | DX51D   | Z275                            |
| KP 2                      | DX51D   | Z275                            |
| KP 9                      | DX51D   | Z275                            |
| KR 4                      | S 235   | Z275                            |
| KR 5                      | DX51D   | Z275                            |
| KR 6                      | DC01    | Fe/Zn 12                        |
| KR 7                      | DC01    | Fe/Zn 12                        |
| KRB 7                     | DC01    | Fe/Zn 12 + Powder Coating 60 μm |
| KSB 1                     | DC01    | Fe/Zn 12 + Powder Coating 60 μm |
| KWB1                      | DC01    | Fe/Zn 12 + Powder Coating 60 μm |
| KWC 1                     | DC01    | Fe/Zn 12 + Powder Coating 60 μm |
| WBZ 14                    | DX51D   | Z275                            |
| PSL 50, 70, 90, 100       | S 235   | Z275                            |
| PSP 70, 90, 100, 120      | S 235   | Z275                            |
| PSPO 80, 100              | S 235   | Z275                            |
| PSR 80, 110               | S 235   | Z275                            |
| PSRT                      | S 235   | Z275                            |
| PSRU                      | S 235   | Z275                            |
| PST 70, 90, 100, 120, 140 | S 235   | Z275                            |
| PS 84 L                   | S 235   | Z275                            |

### 1.1 Identification

The identification parameters and reference to product specifications for identifying the materials and components which constitute the three dimensional nailing plates are given in Annex 1.

## **2 Specification of the intended use(s) in accordance with the applicable European Assessment Document (hereinafter EAD)**

The DMX<sup>®</sup> three-dimensional nailing plates are intended to be used in timber to timber connections as well as connections between a timber joist and a concrete structure or a steel member. For connecting the mutually perpendicular, load-bearing, solid timber elements, in side-grain to side-grain configurations, in joints for which requirements for mechanical resistance and stability in the sense of the basic work requirement 1 of Regulation (EU) No 305/2011 shall be fulfilled.

Ring shank nails according to EN 14592+A1 with the diameter  $\geq 4$  mm, characteristic yield moment  $M_{y,k} = 7168$  N·mm, characteristic withdrawal parameter  $f_{ax,k} = 7.8$  N·mm<sup>-2</sup> and characteristic tensile capacity  $f_{tens,k} = 7.3$  kN shall be used for connections made with the DMX<sup>®</sup> three-dimensional nailing plates.

In respect of the requirements concerning corrosion resistance, DMX<sup>®</sup> three-dimensional nailing plates are for use in timber structures subjected to the internal conditions defined by service classes 1, 2 and 3 (connectors with additional powder coating) according to EN 1995-1-1 (Eurocode 5), in corrosion aggressiveness categories C1 and C2 according to EN ISO 12944-2, without action of acid gases or vapours.

The provisions made in this European Technical Assessment are based on an assumed working life of the product of 50 years. The indications given on the working life cannot be interpreted as a guarantee given by the producer, but are to be regarded only as a means for choosing the right products in relation to the expected economically reasonable working life of the works.

The assessment of the fitness of the DMX<sup>®</sup> three-dimensional nailing plates for the intended use has been made in compliance with the ETAG 015 “*Three-dimensional nailing plates*” used as European Assessment Document (EAD).

### **2.1 Installation of three-dimensional nailing plates**

The installation instructions including special installation techniques and provisions for the qualification of the personnel are given in the manufacturer’s technical documentation.

## **3 Performance of the product and references to the methods used for its assessment**

The assessment of the fitness for use of the DMX<sup>®</sup> three dimensional nailing plates according to the basic work requirements (BWR) were carried out in compliance with ETAG 015.

The European Technical Assessment is issued for the DMX<sup>®</sup> three dimensional nailing plates on the basis of agreed data and information, deposited at Technický a zkušební ústav stavební Praha, s.p., which identifies DMX<sup>®</sup> three dimensional nailing plates that has been assessed and judged. Changes to the plates or production process which could result in this deposited data and information being incorrect should be notified to Technický a zkušební ústav stavební Praha, s.p. before the changes are introduced. Technický a zkušební ústav stavební Praha, s.p. will decide whether or not such changes affect the ETA and consequently the validity of the CE marking on the basis of the ETA and if so whether further assessment or alternations to the ETA shall be necessary.

## Essential characteristics of the product

|  | Essential characteristic                                 | Performance  |
|--|--|--|
| 3.1 BWR 1: Mechanical resistance and stability |  |  |
| 3.1.1  | Joint strength   | See Annex 3  |
| 3.1.2  | Joint stiffness  | NPA  |
| 3.1.3  | Joint ductility in cyclic testing                        | NPA  |
| 3.2 BWR 2: Safety in case of fire              |  |  |
| 3.2.1  | Reaction to fire   | The steel elements are classified as class A1 of reaction to fire (non-combustible products) in accordance with EN 13501-1+A1 and to European Commission Decision 96/603/EC amended by European Commission Decision 2000/605/EC. |
| 3.2.2  | Resistance to fire                                       | NPA  |
| 3.3 BWR 3: Hygiene, health and the environment |  |  |
| 3.3.1  | Content, emission and/or release of dangerous substances | See 3.3.1  |
| BWR 4: Safety and accessibility in use         |  |  |
| Not relevant                                   |  |  |
| BWR 5: Protection against noise                |  |  |
| Not relevant                                   |  |  |
| BWR 6: Energy economy and heat retention       |  |  |
| Not relevant                                   |  |  |
| BWR 7: Sustainable use of natural resources    |  |  |
| Not relevant                                   |  |  |

### 3.1 Mechanical resistance and stability (BWR 1)

#### 3.1.1 Joint strength

The characteristic load-carrying capacities of joints loaded according to static diagrams (shown in Annex 2), determined by tests or calculations carried out according to ETAG 015, clause 5.1.3 and EN 1995-1-1 are given in Annex 3. The characteristic load-carrying capacities of joints for other load directions shall be calculated on the basis of EN 1995-1-1 (Eurocode 5) or according to national regulations. The design values shall be determined according to EN 1995-1-1 (Eurocode 5).

Following the requirements of ETAG 015 for the minimum number of specimens for determining the characteristic load-bearing capacities through testing the applicant provided the laboratory with 5 specimens of each test assembly distinguished by a connector type, configuration of the connection and static scheme (direction of force actions).

The modifications of standard procedures applied come from the requirements of ETAG 015. The procedure specified in standard ref. 6 is modified as required in EOTA TR 016 *Method of testing "Three-Dimensional Nailing Plates, with examples"*, namely the procedure corresponding to the case "Test specimens fulfil EN ISO 8970", which as stated above was relevant in all cases.

As agreed in between the applicant and the laboratory, conditioning and transportation of the test assemblies into the laboratory was carried out by the applicant under specified conditions.

The conditions were as follows:

The timber members used – sawn timber blanks of European whitewood, grade C24, free from major defects in the area of the connector. Selection of timber members within a test

group (the five specimens) referring to densities should comply with the requirements of EN ISO 8970. During testing of connectors were used timber specimens with characteristic density about  $450 \text{ kg}\cdot\text{m}^{-3}$ .

The samples came in four successive deliveries in condition “fit for direct testing” meaning that conditioning the timber elements to equilibrium moisture content in line with the requirements of cl. 2.4.1.1.3.3. ETAG 015 was carried out by the applicant. The completed and conditioned test assemblies were delivered protected by a plastic wrap.

Conditioning in the laboratory consisted in equalisation of temperatures of the specimens and the ambient temperature by storing in the laboratory for 3 days as a minimum, during which time the specimens remained wrapped in plastic cover. In the majority of cases the term of storing was much longer.

Dimensions of the timber members, relative moisture content and weight of the assemblies were determined for control whether the density of timber blanks complies with the requirements of EN ISO 8970. This was carried out with specimens unwrapped just before the load testing of each specimen. It is stated that in the majority of cases the requirement of the standard have been met. In several cases when the mean wood density was above the scope stated by the standard, allowance was made in line with the respective provision of EOTA TR 016.

### **3.1.2 Joint stiffness**

No performance assessed.

### **3.1.3 Joint ductility in cyclic testing**

No performance assessed.

## **3.2 Safety in case of fire (BWR 2)**

### **3.2.1 Reaction to fire**

The steel elements are classified as class A1 of reaction to fire (non-combustible products) in accordance with EN 13501-1+A1 and to European Commission Decision 96/603/EC amended by European Commission Decision 2000/605/EC.

### **3.2.2 Resistance to fire**

Performance in relation to fire resistance would be determined for the complete structural element with any associated finishes, therefore there is no performance assessed option used to this Basic Work Requirement.

## **3.3 Hygiene, health and the environment (BWR 3)**

### **3.3.1 Content, emission and/or release of dangerous substances**

The manufacturer submit a written declaration whether or not and in which concentration the DMX® three dimensional nailing plates contain substances which are classified as dangerous according to Directive 67/548/EEC and European Commission Regulation No 1272/2008.

In addition to the specific clauses relating to dangerous substances, there may be other requirements applicable to the products falling within their scope (e.g. transposed European legislation and national laws, regulations and administrative provisions). In order to meet the provisions of the Construction Products Regulation, these requirements need also to be complied with, when and where they apply.

## **3.4 Safety and accessibility in use (BWR 4)**

Not relevant.

### **3.5 Protection against noise (BWR 5)**

Not relevant.

### **3.6 Energy economy and heat retention (BWR 6)**

Not relevant.

### **3.7 Sustainable use of natural resources (BWR 7)**

For the sustainable use of natural resources no performance was assessed for this product.

### **3.8 Aspects of durability, serviceability and identification**

#### **3.8.1 Durability and serviceability**

The DMX<sup>®</sup> three-dimensional nailing plates have been assessed as having satisfactory durability and serviceability when used in conditions defined by service classes 1 and 2 according to EN 1995-1-1 (Eurocode 5).

#### **3.8.2 Identification**

Each three-dimensional nailing plate is to be marked with the symbol and the product type according to the Annex 1.

#### **4 Assessment and verification of constancy of performance (Hereinafter AVCP) system applied, with reference to its legal base**

According to the decision 1997/638/EC<sup>1</sup>, of the European Commission the system(s) of assessment and verification of constancy of performance (see Annex V to Regulation (EU) No 305/2011 and Commission delegated Regulation (EU) No 568/2014) given in the following table applies:

| Product(s)   | Intended use(s)                | Level(s) or class(es) | Attestation of conformity system(s) |
|--|--------------------------------|-----------------------|-------------------------------------|
| <b>Shear plates, toothed-plate connectors, punched nail plates, nailing plates</b> | For structural timber products |                       | 2+                                  |

#### **5 Technical details necessary for the implementation of the AVCP system, as provided for in the applicable EAD**

Technical details necessary for the implementation of the AVCP system are laid down in the control plan deposited at Technický a zkušební ústav stavební Praha, s.p.

Issued in Prague on 28.04.2020

By  
Mária Schaan  
Head of the TAB

Annexes:

- Annex 1 Product details and definitions
- Annex 2 Loading according to static diagrams  
Calculations according to static diagrams
- Annex 3 The characteristic load-carrying capacities of connectors
- Annex 4 Nailing patterns
- Annex 5 Specification of connection elements
- Annex 6 Reference documents

---

<sup>1</sup> Official Journal of the European Communities L 268/36 of 19.9.1997

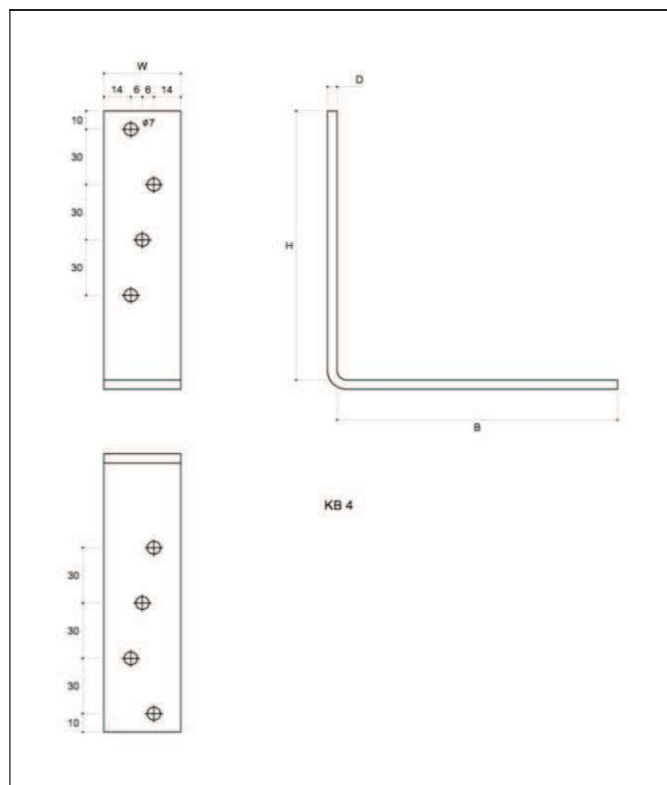

Figure 1 Type KB 4

Table 2 KB three-dimensional nailing plate symbols and dimensions

| Symbol | Dimensions, mm |     |     |   | Quantity of openings |
|--------|----------------|-----|-----|---|----------------------|
|        | W              | H   | B   | D | ø7                   |
| KB 4   | 40             | 146 | 146 | 5 | 8                    |





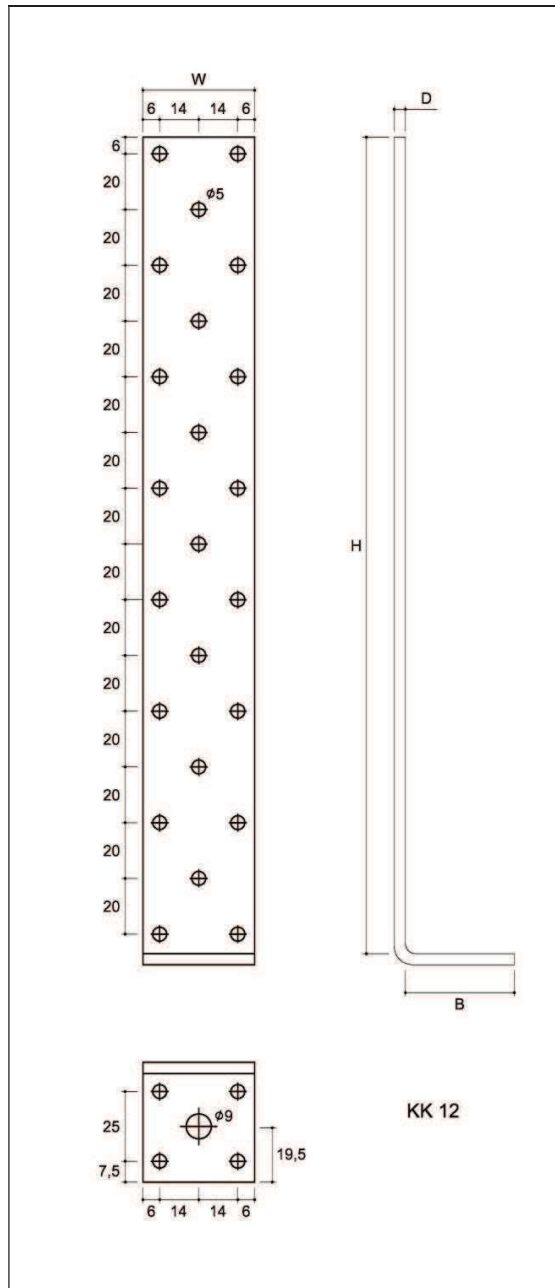

**Figure 4** Type KK 12

**Table 4** KK three-dimensional nailing plate symbols and dimensions

| Symbol | Dimensions, mm |     |    |   | Quantity of openings |          |
|--------|----------------|-----|----|---|----------------------|----------|
|        | W              | H   | B  | D | $\phi 5$             | $\phi 9$ |
| KK 12  | 40             | 296 | 39 | 4 | 27                   | 1        |

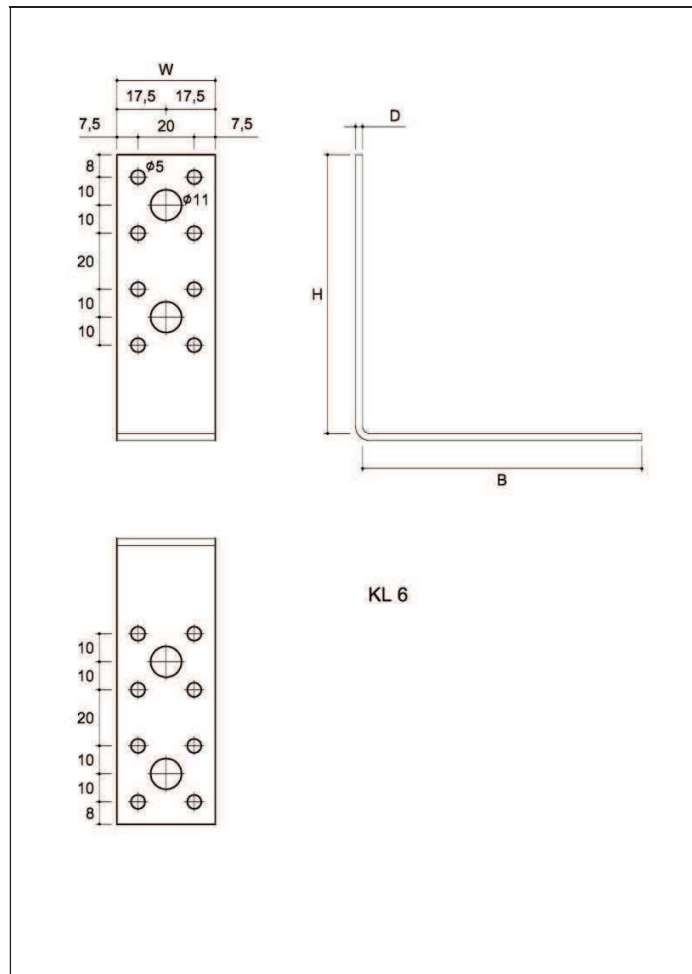

Figure 5 Type KL 6

Table 5 KL three-dimensional nailing plate symbols and dimensions

| Symbol | Dimensions, mm |      |      |     | Quantity of openings |     |
|--------|----------------|------|------|-----|----------------------|-----|
|        | W              | H    | B    | D   | ø5                   | ø11 |
| KL 6   | 35             | 99.5 | 99.5 | 2.5 | 16                   | 4   |

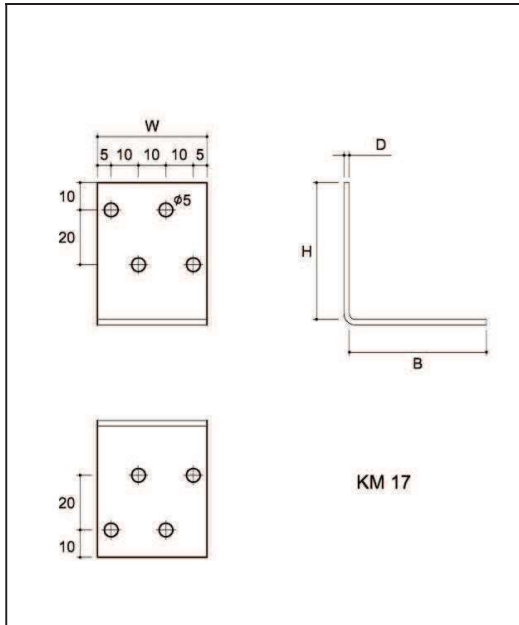

Figure 6 Type KM 17

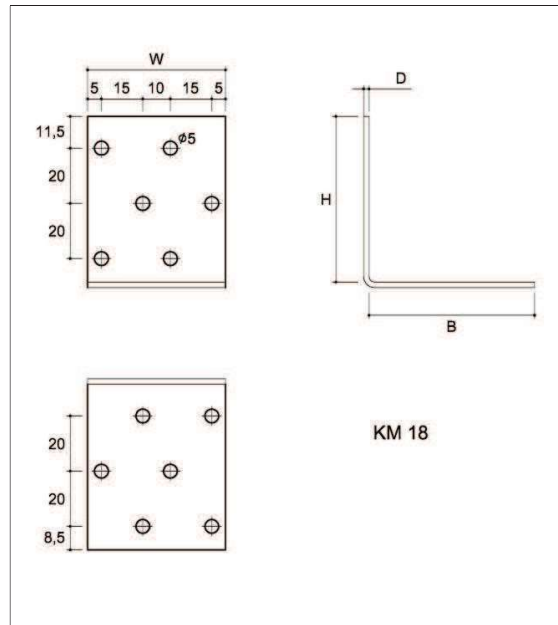

Figure 7 Type KM 18

Table 6 KM three-dimensional nailing plate symbols and dimensions

| Symbol | Dimensions, mm |    |    |   | Quantity of openings |  |
|--------|----------------|----|----|---|----------------------|--|
|        | W              | H  | B  | D | ø5                   |  |
| KM 17  | 40             | 50 | 50 | 2 | 8                    |  |
| KM 18  | 50             | 60 | 60 | 2 | 12                   |  |

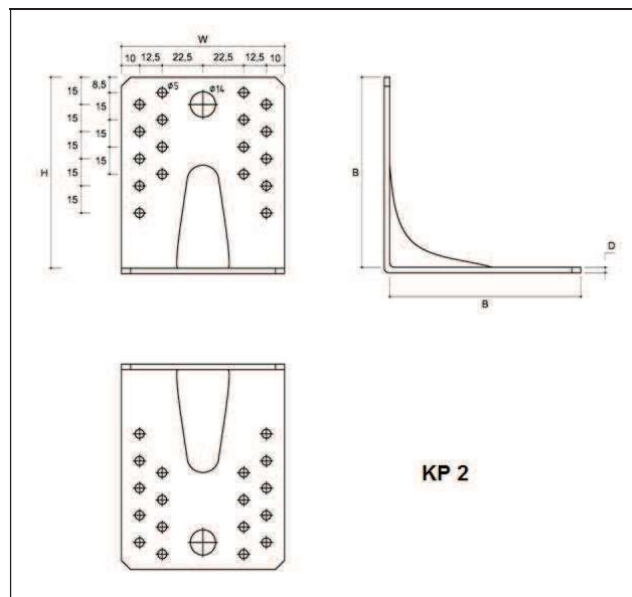
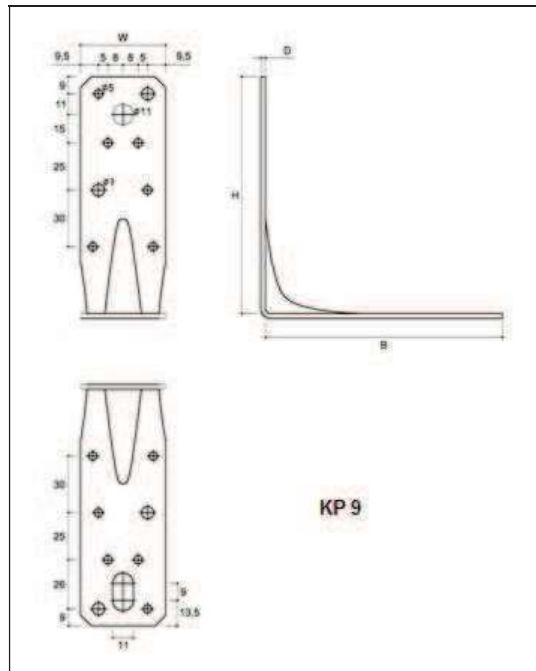

Figure 8 Type KP 2

Table 7 KP three-dimensional nailing plate symbols and dimensions

| Symbol | Dimensions, mm |       |       |   | Quantity of openings |     |
|--------|----------------|-------|-------|---|----------------------|-----|
|        | W              | H     | B     | D | ø5                   | ø14 |
| KP 2   | 90             | 105.5 | 105.5 | 3 | 36                   | 2   |



**Figure 9** Type KP 9

**Table 8** KP three-dimensional nailing plate symbols and dimensions

| Symbol | Dimensions, mm |     |     |     | Quantity of openings |    |     |
|--------|----------------|-----|-----|-----|----------------------|----|-----|
|        | W              | H   | B   | D   | ∅5                   | ∅7 | ∅11 |
| KP 9   | 45             | 126 | 126 | 2.5 | 12                   | 4  | 1   |

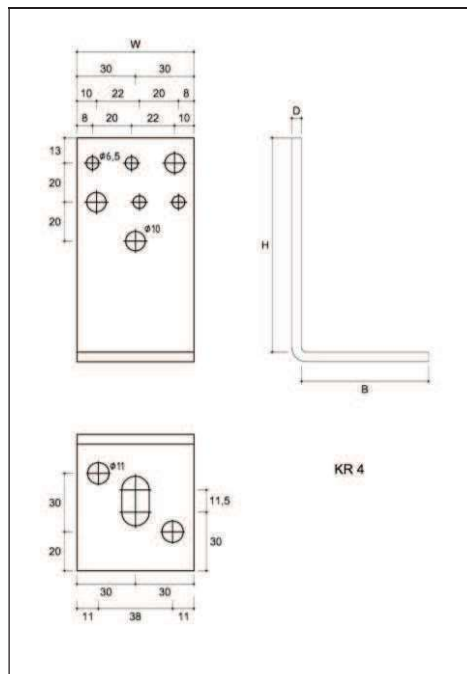

**Figure 10** Type KR 4

**Table 9** KR three-dimensional nailing plate symbols and dimensions

| Symbol | Dimensions, mm |     |    |   | Quantity of openings |     |     |
|--------|----------------|-----|----|---|----------------------|-----|-----|
|        | W              | H   | B  | D | ∅6.5                 | ∅10 | ∅11 |
| KR 4   | 60             | 110 | 65 | 5 | 4                    | 3   | 2   |

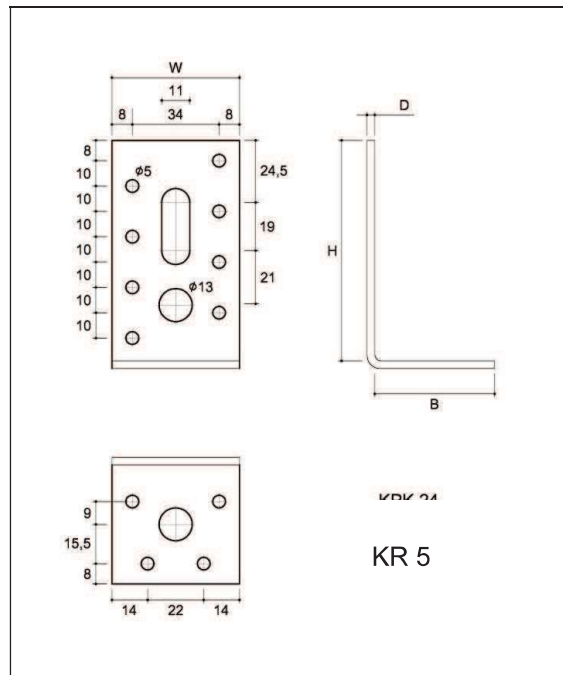

Figure 11 Type KR 5

Table 10 KR three-dimensional nailing plate symbols and dimensions

| Symbol | Dimensions, mm |    |    |   | Quantity of openings |     |
|--------|----------------|----|----|---|----------------------|-----|
|        | W              | H  | B  | D | ø5                   | ø13 |
| KR 5   | 50             | 87 | 47 | 3 | 12                   | 2   |

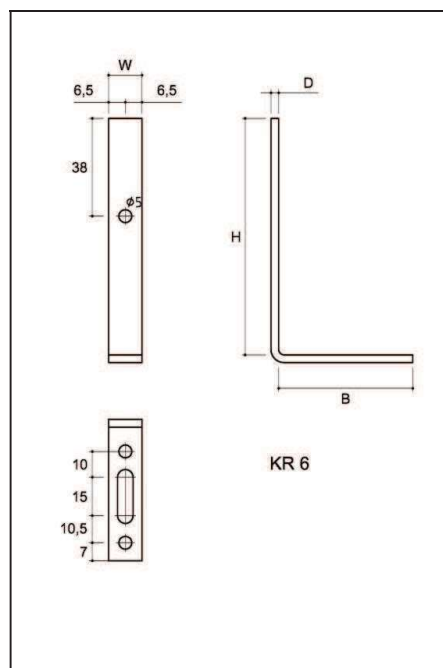
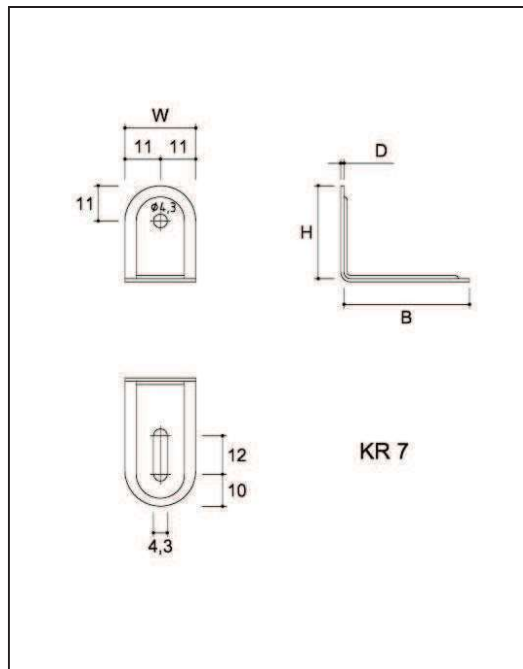

Figure 12 Type KR 6

Table 11 KR three-dimensional nailing plate symbols and dimensions

| Symbol | Dimensions, mm |    |    |   | Quantity of openings |
|--------|----------------|----|----|---|----------------------|
|        | W              | H  | B  | D | ø5                   |
| KR 6   | 13             | 92 | 52 | 3 | 3                    |



**Figure 13** Type KR 7, KRB 7

**Table 12** KR, KRB three-dimensional nailing plate symbols and dimensions

| Symbol | Dimensions, mm |    |    |   | Quantity of openings |
|--------|----------------|----|----|---|----------------------|
|        | W              | H  | B  | D |                      |
| KR 7   | 22             | 29 | 39 | 1 | 1                    |
| KRB 7  | 22             | 29 | 39 | 1 | 1                    |

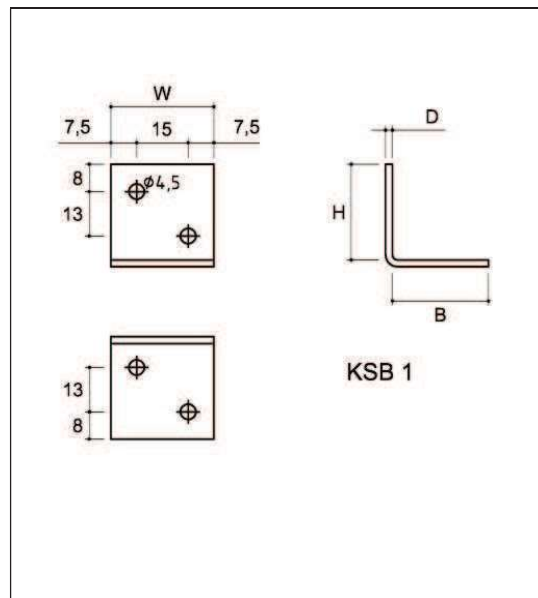

**Figure 14** Type KSB 1

**Table 13** KSB three-dimensional nailing plate symbols and dimensions

| Symbol | Dimensions, mm |    |    |   | Quantity of openings |
|--------|----------------|----|----|---|----------------------|
|        | W              | H  | B  | D |                      |
| KSB 1  | 30             | 28 | 28 | 2 | 4                    |

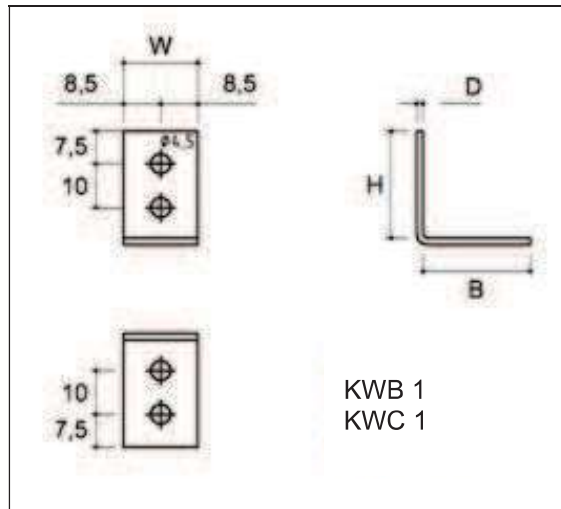

**Figure 15** Type KWB 1, KWC 1

**Table 14** KWB, KWC three-dimensional nailing plate symbols and dimensions

| Symbol | Dimensions, mm |      |      |   | Quantity of openings |
|--------|----------------|------|------|---|----------------------|
|        | W              | H    | B    | D |                      |
| KWB 1  | 17             | 24.5 | 24.5 | 2 | 4                    |
| KWC 1  | 17             | 24.5 | 24.5 | 2 | 4                    |

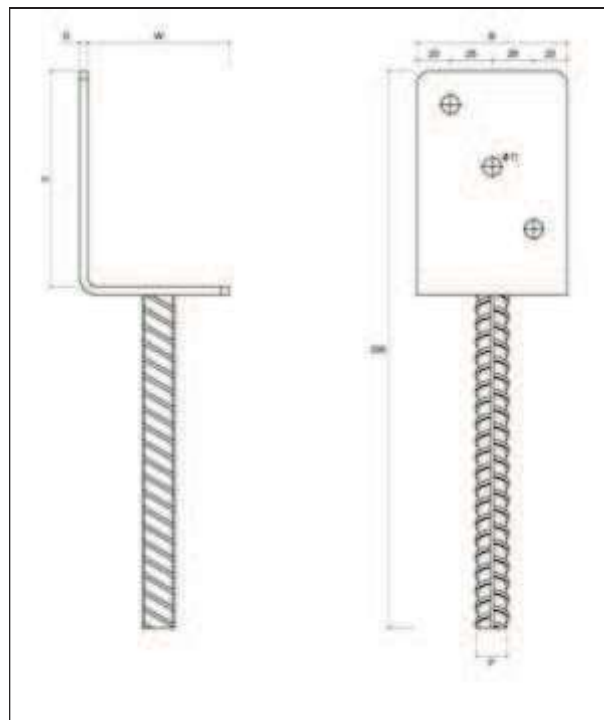
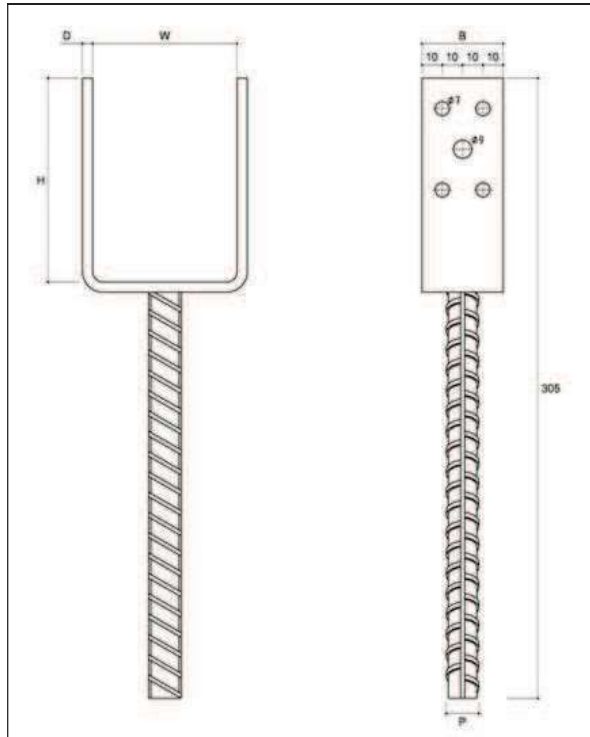

**Figure 16** Type PS 84L

**Table 15** PS 84 three-dimensional nailing plate symbols and dimensions

| Symbol | Dimensions, mm |     |    |   |    | Quantity of openings |
|--------|----------------|-----|----|---|----|----------------------|
|        | W              | H   | B  | D | P  |                      |
| PS 84L | 90             | 130 | 90 | 5 | 18 | 3                    |

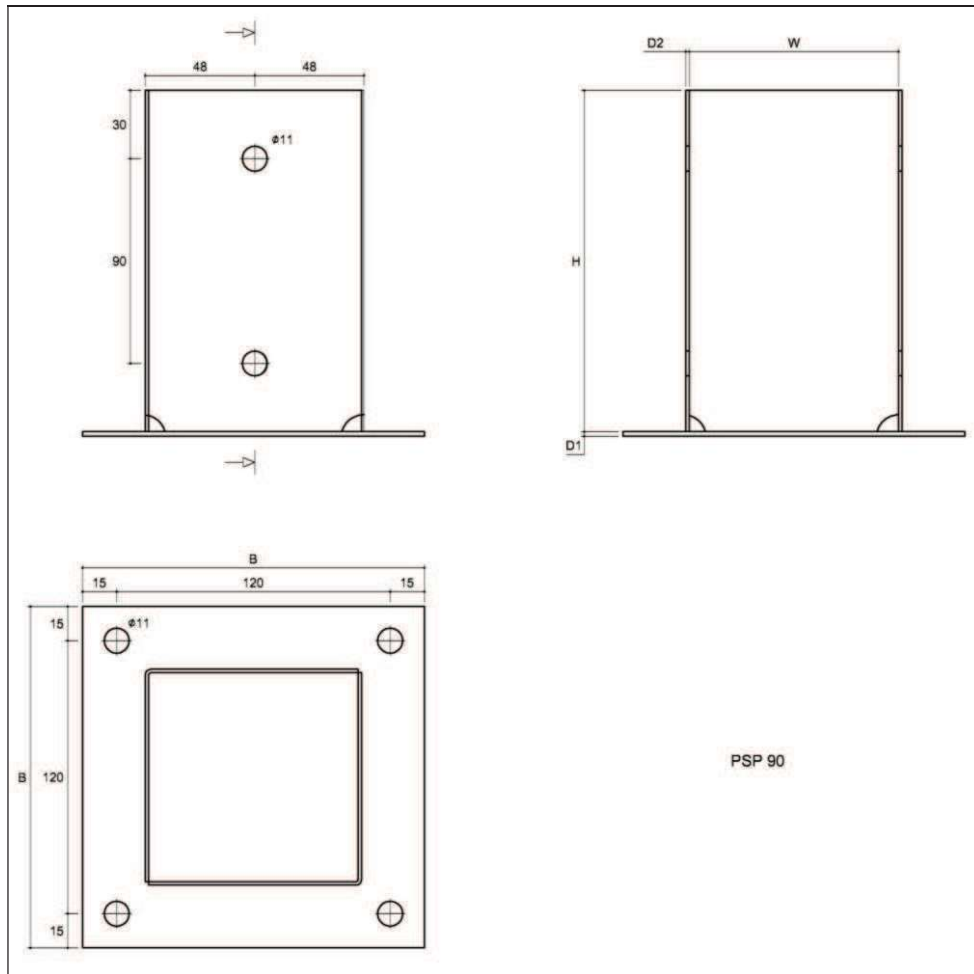



**Figure 17** Type PSL 70

**Table 16** PSL three-dimensional nailing plate symbols and dimensions

| Symbol  | Dimensions, mm |     |    |   |     | Quantity of openings |    |
|---------|----------------|-----|----|---|-----|----------------------|----|
|         | W              | H   | B  | D | P   | ø7                   | ø9 |
| PSL 50  | 51             | 100 | 40 | 5 | ø16 | 8                    | 2  |
| PSL 70  | 71             | 100 | 40 | 5 | ø16 | 8                    | 2  |
| PSL 90  | 91             | 100 | 40 | 5 | ø16 | 8                    | 2  |
| PSL 100 | 101            | 100 | 40 | 5 | ø16 | 8                    | 2  |



**Figure 18** Type PSP 90

**Table 17** PSP three-dimensional nailing plate symbols and dimensions

| Symbol  | Dimensions, mm |     |     |    |     | Quantity of openings |
|---------|----------------|-----|-----|----|-----|----------------------|
|         | W              | H   | B   | D1 | D2  | Ø11                  |
| PSP 70  | 72             | 150 | 150 | 2  | 1.5 | 8                    |
| PSP 90  | 92             | 150 | 150 | 2  | 1.5 | 8                    |
| PSP 100 | 102            | 150 | 150 | 2  | 2   | 8                    |
| PSP 120 | 122            | 150 | 180 | 2  | 2   | 8                    |

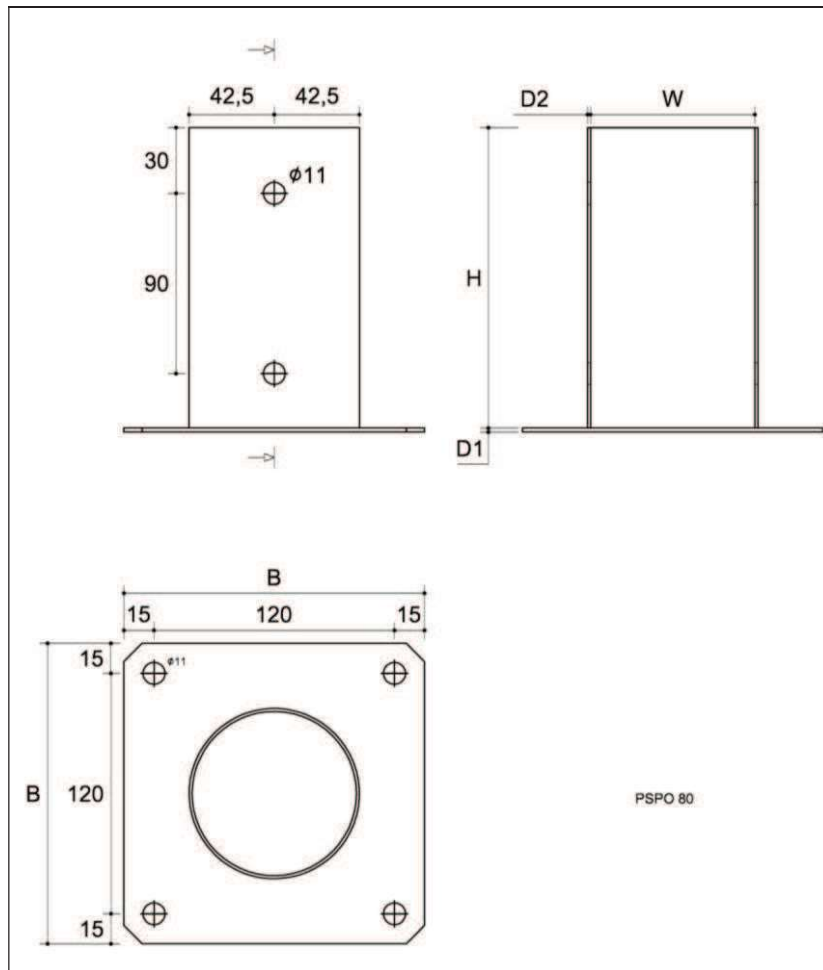

**Figure 19** Type PSPO 80

**Table 18** PSPO three-dimensional nailing plate symbols and dimensions

| Symbol   | Dimensions, mm |     |     |    |     | Quantity of openings |
|----------|----------------|-----|-----|----|-----|----------------------|
|          | W              | H   | B   | D1 | D2  | ∅11                  |
| PSPO 80  | ∅82            | 150 | 150 | 2  | 1.5 | 8                    |
| PSPO 100 | ∅102           | 150 | 150 | 2  | 1.5 | 8                    |

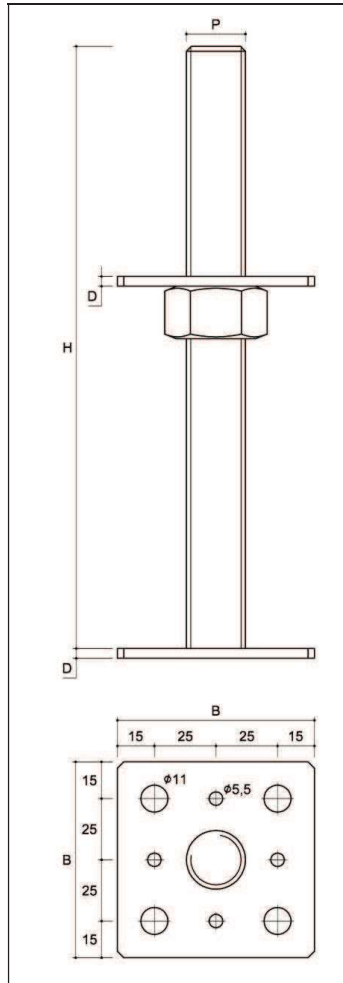

**Figure 20** Type PSR 80

**Table 19** PSR three-dimensional nailing plate symbols and dimensions

| Symbol  | Dimensions, mm |     |   |     | Quantity of openings |           |
|---------|----------------|-----|---|-----|----------------------|-----------|
|         | H              | B   | D | P   | $\phi 5.5$           | $\phi 11$ |
| PSR 80  | 246            | 80  | 4 | M24 | 8                    | 8         |
| PSR 110 | 246            | 110 | 4 | M24 | 8                    | 8         |

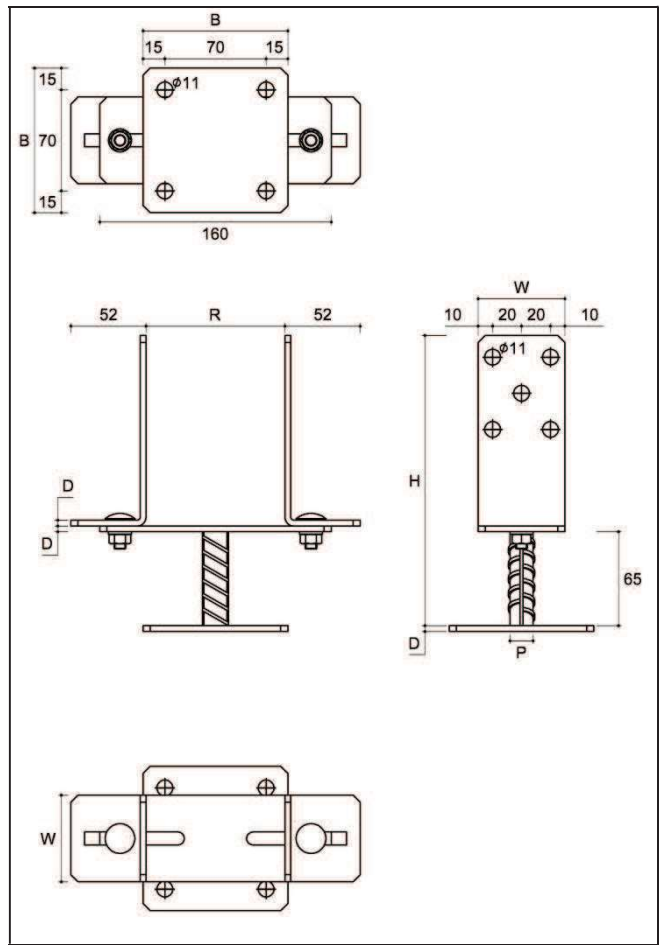

Figure 21 Type PSRT

Table 20 PSRT three-dimensional nailing plate symbols and dimensions

| Symbol | Dimensions of the timber beam | Dimensions, mm |     |     |   |    |     | Quantity of openings |
|--------|-------------------------------|----------------|-----|-----|---|----|-----|----------------------|
|        | [mm]                          | W              | H   | B   | D | R  | P   | Ø11                  |
| PSRT   | 60x120                        | 60             | 200 | 100 | 4 | 60 | Ø18 | 14                   |
|        | 70x120                        | 60             | 200 | 100 | 4 | 70 | Ø18 | 14                   |
|        | 80x120                        | 60             | 200 | 100 | 4 | 80 | Ø18 | 14                   |
|        | 90x120                        | 60             | 200 | 100 | 4 | 90 | Ø18 | 14                   |

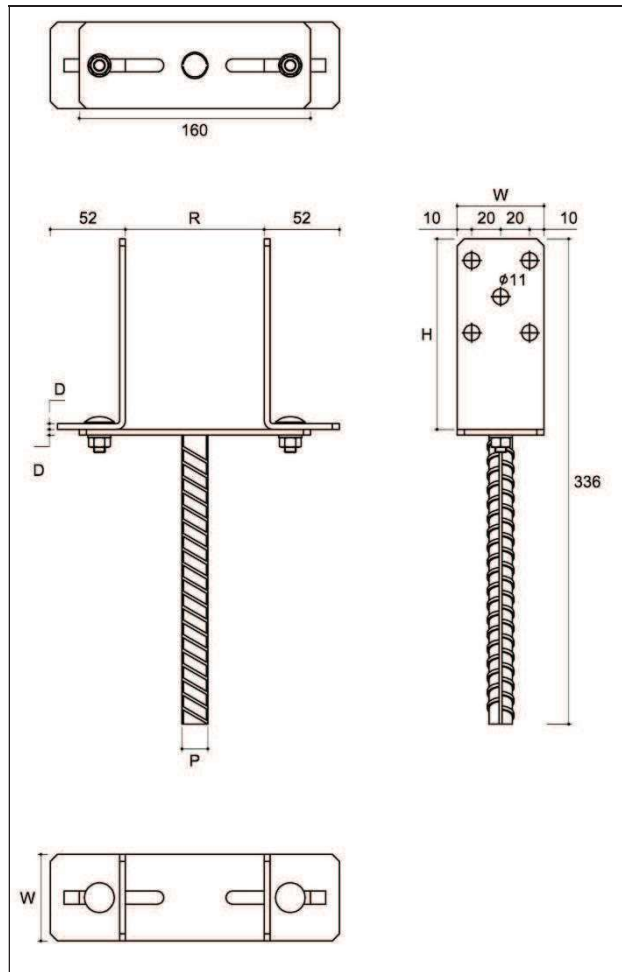

Figure 22 Type PSRU

Table 21 PSRU three-dimensional nailing plate symbols and dimensions

| Symbol | Dimensions of the timber beam | Dimensions, mm |     |     |    |   | Quantity of openings |
|--------|-------------------------------|----------------|-----|-----|----|---|----------------------|
|        | [mm]                          | W              | H   | P   | R  | D | ø11                  |
| PSRU   | 60x120                        | 60             | 132 | ø18 | 60 | 4 | 10                   |
|        | 70x120                        | 60             | 132 | ø18 | 70 | 4 | 10                   |
|        | 80x120                        | 60             | 132 | ø18 | 80 | 4 | 10                   |
|        | 90x120                        | 60             | 132 | ø18 | 90 | 4 | 10                   |

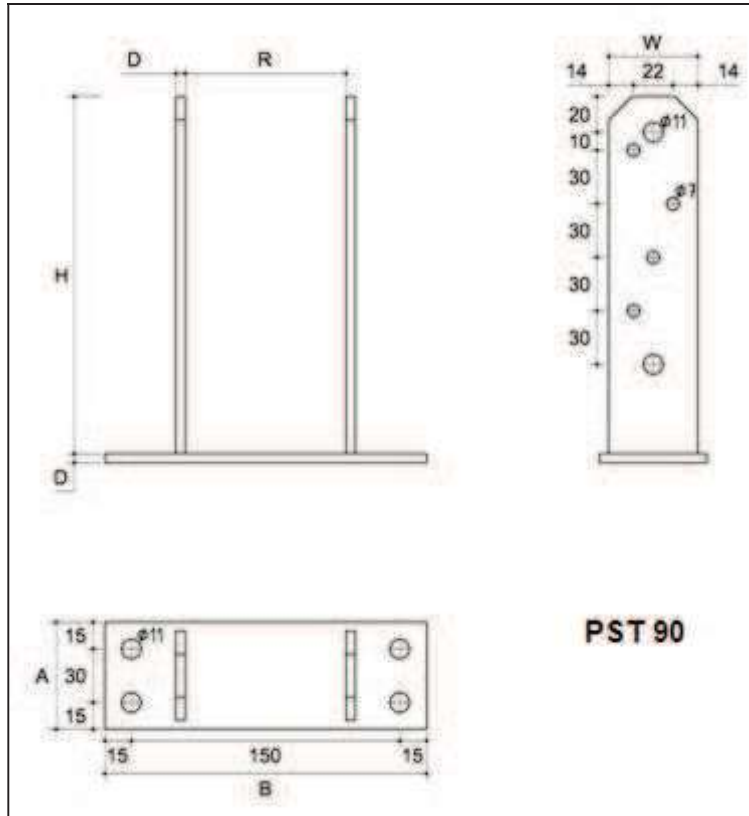
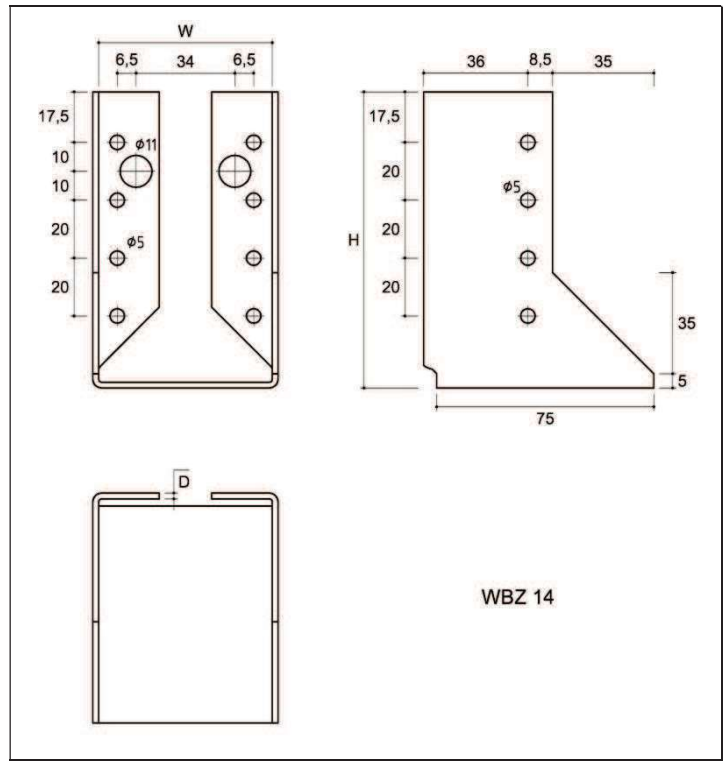

Figure 23 Type PST 90

Table 22 PST three-dimensional nailing plate symbols and dimensions

| Symbol  | Dimensions, mm |     |     |    |     |   | Quantity of openings |     |
|---------|----------------|-----|-----|----|-----|---|----------------------|-----|
|         | W              | H   | R   | A  | B   | D | ø7                   | ø11 |
| PST 70  | 50             | 200 | 70  | 60 | 160 | 5 | 8                    | 8   |
| PST 90  | 50             | 200 | 90  | 60 | 180 | 5 | 8                    | 8   |
| PST 100 | 50             | 200 | 100 | 60 | 190 | 5 | 8                    | 8   |
| PST 120 | 50             | 200 | 120 | 60 | 210 | 5 | 8                    | 8   |
| PST 140 | 50             | 200 | 140 | 60 | 230 | 5 | 8                    | 8   |



**Figure 24** Type WBZ 14

**Table 23** WBZ 14 three-dimensional nailing plate symbols and dimensions

| Symbol | Dimensions, mm |     |   | Quantity of openings |           |
|--------|----------------|-----|---|----------------------|-----------|
|        | W              | H   | D | $\phi 5$             | $\phi 11$ |
| WBZ 14 | 60             | 102 | 2 | 16                   | 2         |



## CONNECTION ELEMENTS

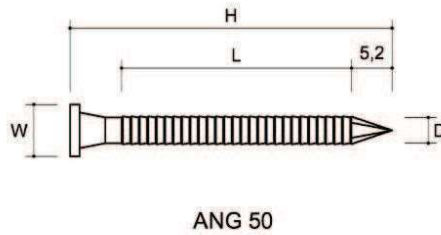

**Figure 25** Type ANG 50

**Table 24** ANCHOR dowel type connector symbols and dimensions

| Symbol | Dimensions, mm |    |      |   |
|--------|----------------|----|------|---|
|        | D              | H  | L    | W |
| ANG 50 | 4              | 50 | 36.8 | 8 |

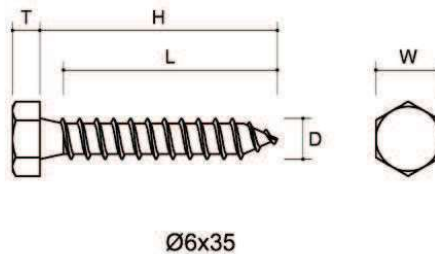

**Figure 26** Type 6x35

**Table 25** ø6x35 type connector symbols and dimensions

| Symbol | Dimensions, mm |    |    |     |   | Standard |
|--------|----------------|----|----|-----|---|----------|
|        | D              | H  | L  | W   | T |          |
| ø6x35  | 6              | 35 | 31 | 9.7 | 4 | DIN 571  |

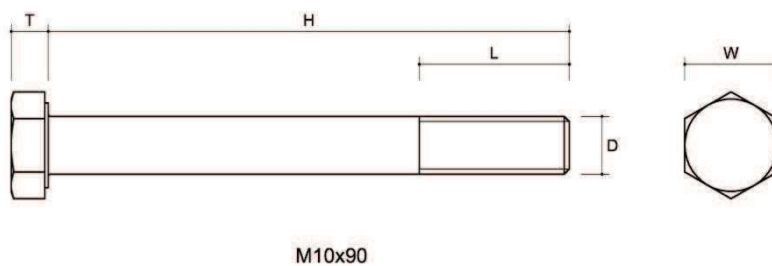
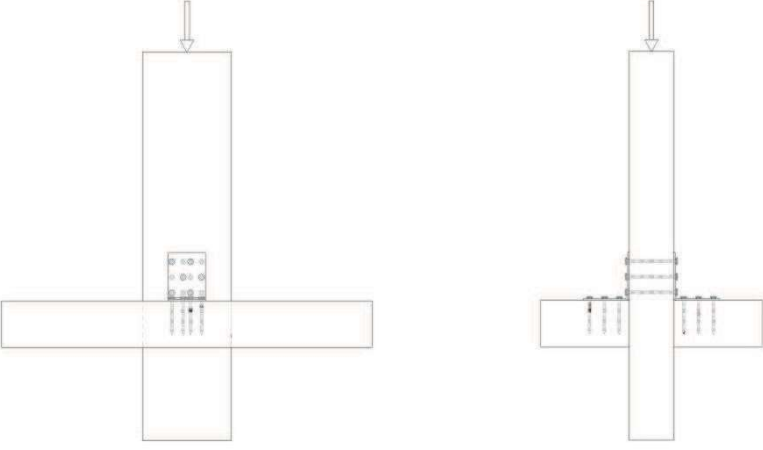

**Figure 27** Type M10x90

**Table 26** M bolt type connector symbols and dimensions

| Symbol  | Dimensions, mm |     |    |    |     | Standard |
|---------|----------------|-----|----|----|-----|----------|
|         | D              | H   | L  | W  | T   |          |
| M12x110 | 12             | 110 | 30 | 18 | 7.5 | ISO 4014 |
| M10x160 | 10             | 160 | 32 | 16 | 6.5 | ISO 4014 |
| M10x140 | 10             | 140 | 32 | 16 | 6.5 | ISO 4014 |
| M10x130 | 10             | 130 | 32 | 16 | 6.5 | ISO 4014 |

| Symbol  | Dimensions, mm |     |    |    |     | Standard |
|---------|----------------|-----|----|----|-----|----------|
|         | D              | H   | L  | W  | T   |          |
| M10x120 | 10             | 120 | 26 | 16 | 6.5 | ISO 4014 |
| M10x110 | 10             | 110 | 26 | 16 | 6.5 | ISO 4014 |
| M10x90  | 10             | 90  | 26 | 16 | 6.5 | ISO 4014 |
| M10x70  | 10             | 70  | 26 | 16 | 6.5 | ISO 4014 |
| M8x120  | 8              | 120 | 22 | 13 | 5.2 | ISO 4014 |
| M8x110  | 8              | 110 | 22 | 13 | 5.2 | ISO 4014 |
| M8x100  | 8              | 100 | 22 | 13 | 5.2 | ISO 4014 |
| M8x90   | 8              | 90  | 22 | 13 | 5.2 | ISO 4014 |
| M8x70   | 8              | 70  | 22 | 13 | 5.2 | ISO 4014 |

| No. | Scheme   | Connector types  |
|-----|--|--|
| 1   |  | KB 4<br>KK 0<br>KL 6<br>KM 17<br>KM 18<br>KP 2<br>KP 9<br>KR 5<br>KR 6<br>KR 7<br>KRB 7<br>KSB 1<br>KWB 1<br>KWC 1 |

**Figure 28** Scheme 1

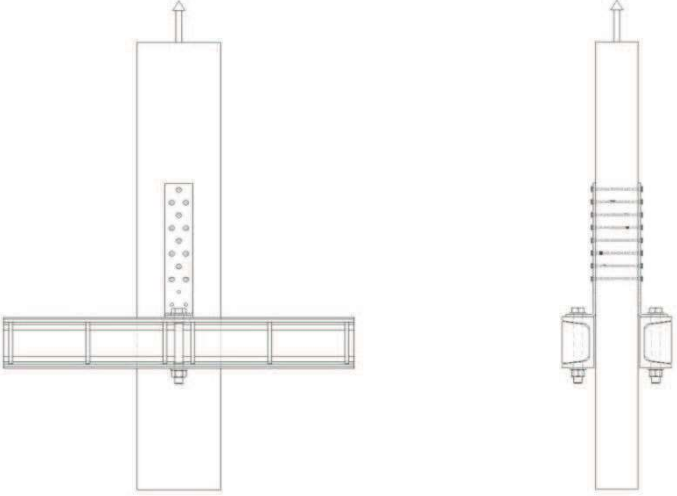
| No. | Scheme   | Connector types        |
|-----|--|------------------------|
| 2   |  | KK 11<br>KK 12<br>KR 4 |

**Figure 29** Scheme 2

| No. | Scheme | Connector type |
|-----|--------|----------------|
| 3   |        | WBZ 14         |

Figure 30 Scheme 3

| No. | Scheme | Connector type                        |
|-----|--------|---------------------------------------|
| 4   |        | PSL 50<br>PSL 70<br>PSL 90<br>PSL 100 |

Figure 31 Scheme 4

| No. | Scheme | Connector type   |
|-----|--------|--|
| 5   |        | PSP 70<br>PSP 90<br>PSP 100<br>PSP 120<br>PSPO 80<br>PSPO 100<br>PST 70<br>PST 90<br>PST 100<br>PST 120<br>PST 140 |

Figure 32 Scheme 5

| No. | Scheme  | Connector type    |
|-----|---|-------------------|
| 6   |  | PSR 80<br>PSR 110 |

Figure 33 Scheme 6

| No. | Scheme  | Connector type |
|-----|---|----------------|
| 7   |  | PSRT           |

Figure 34 Scheme 7

| No. | Scheme   | Connector type |
|-----|--|----------------|
| 8   |  | PSRU           |

Figure 35 Scheme 8

| No. | Scheme   | Connector type |
|-----|--|----------------|
| 9   |  | PS 84L         |

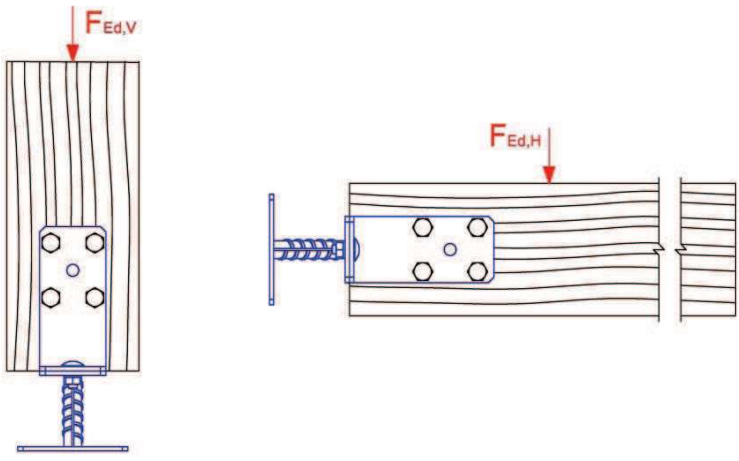
Figure 36 Scheme 9

|   |  |                |  |
|---|--|----------------|--|
| <b>DMX®</b>   |  | <b>ANNEX 3</b> |  |
| <b>THE CHARACTERISTIC LOAD-CARRYING CAPACITIES OF CONNECTORS (LOAD)</b> |  | ETA 15/0725    |  |

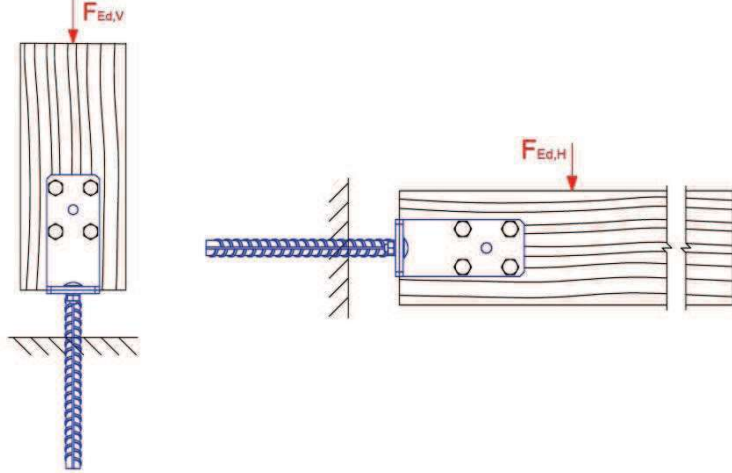
Table 27

| Connector | Type of Load | Timber Moisture [%] | Density $\rho_{mean, 12\%}$ [kg*m <sup>-3</sup> ] | $P_{max, mean}$ (350 kg*m <sup>-3</sup> ) [kN] | $P_{max, k}$ (350 kg*m <sup>-3</sup> ) [kN] | Connectors per connection | Method of determination | Document No.     | Note |
|-----------|--------------|---------------------|---|--|---|---------------------------|-------------------------|------------------|------|
| KB 4      | pressure     | 12.7                | 420   | 21.9   | 19.3  | 2                         | testing                 | KB4-01-0001/15   | 2)   |
| KK 0      | pressure     | 12                  | 411   | 9.7  | 7.7   | 2                         | testing                 | KK0-01-0001/15   | 2)   |
| KK 11     | pull out     | 11.7                | 429   | 32.8   | 26.5  | 2                         | testing                 | KK11-01-0001/15  | 2)   |
| KK 12     | pull out     | 11.4                | 439   | 20.7   | 18.3  | 2                         | testing                 | KK12-01-0001/15  | 2)   |
| KL 6      | pressure     | 11.9                | 435   | 16.2   | 13.6  | 2                         | testing                 | KL6-01-0001/15   | 2)   |
| KM 17     | pressure     | 11.4                | 456   | 11.2   | 9.3   | 2                         | testing                 | KM17-01-0001/15  | 2)   |
| KM 18     | pressure     | 14.3                | 437   | 13.5   | 11.2  | 2                         | testing                 | KM18-01-0001/15  | 2)   |
| KP 2      | pressure     | 11                  | C24   | 24.3   | 21.9  | 2                         | testing                 | LCE-O-ML-01      | 2)   |
| KP 9      | pressure     | 12.2                | 440   | 21.6   | 18.2  | 2                         | testing                 | KP130-01-0001/15 | 2)   |
| KR 4      | pull out     | 11.4                | 461   | 17.4   | 14.9  | 2                         | testing                 | KR4-01-0001/15   | 2)   |
| KR 5      | pressure     | 11.5                | 450   | 17.4   | 14.7  | 2                         | testing                 | KR5-01-0001/15   | 2)   |
| KR 6      | pressure     | 11.7                | 429   | 7.7  | 6.7   | 2                         | testing                 | KR6-01-0001/15   | 2)   |
| KR 7      | pressure     | 11.3                | 414   | 3.5  | 3   | 2                         | testing                 | KR7-01-0001/15   | 2)   |
| KRB 7     | pressure     | 11.3                | 414   | 3.5  | 3   | 2                         | testing                 | KR7-01-0001/15   | 2)   |
| KSB 1     | pressure     | -                   | C24   | 3.7  | 3.4   | 2                         | testing                 | LCE-O-ML-01      | 2)   |
| KWB 1     | pressure     | 13.8                | 439   | 5.7  | 5   | 2                         | testing                 | KWC1-01-0001/15  | 2)   |

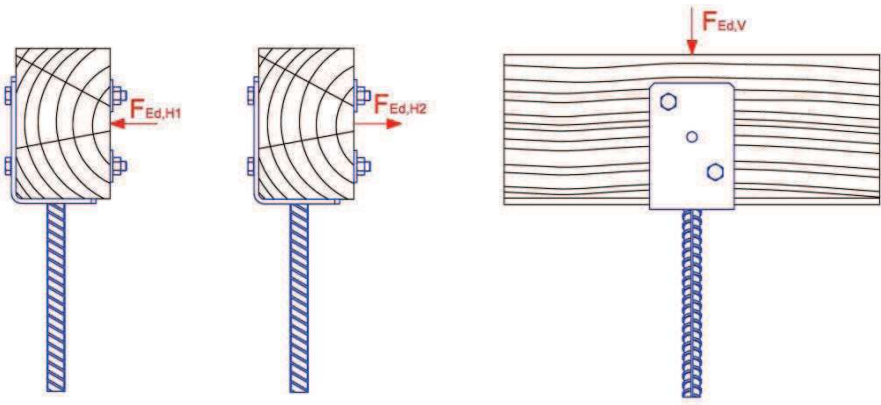
| Connector | Type of Load | Timber Moisture [%] | Density $\rho_{mean}^{12\%}$ [kg*m <sup>-3</sup> ] | $P_{max,mean}$ (350 kg*m <sup>-3</sup> ) [kN] | $P_{max,k}$ (350 kg*m <sup>-3</sup> ) [kN] | Connectors per connection | Method of determination | Document No.     | Note |
|-----------|--------------|---------------------|--|---|--|---------------------------|-------------------------|------------------|------|
| KWC 1     | pressure     | 13.8                | 439  | 5.7   | 5  | 2                         | testing                 | KWC1-01-00001/15 | 2)   |
| WBZ 14    | pressure     | -                   | C24  | -   | 9.3  | 1                         | calculation             | LCE-O-WBZ-01     | 1)   |

Notes:

- 1) The forces are given for the complete connection consisting of one connector
  - 2) The forces are given for the complete connection consisting of two connectors, hence force per one connector (one angle bracket) is half of the given value.
- $P_{max,k}$  characteristic load-bearing capacity of connector



## THE CHARACTERISTIC LOAD-CARRYING CAPACITIES OF CONNECTORS (CALCULATIONS)

Table 28

| Connector | Beam dimensions [mm] | Pressure $F_{Ed,V}$         |                            | Shear $F_{Ed,H1}$            |                             | Shear $F_{Ed,H2}$            |                             | Document No.  |
|-----------|----------------------|-----------------------------|----------------------------|------------------------------|-----------------------------|------------------------------|-----------------------------|---------------|
|           |                      | Timber<br>$N_{Rk,V,w}$ [kN] | Steel<br>$N_{Rd,V,s}$ [kN] | Timber<br>$N_{Rk,H1,w}$ [kN] | Steel<br>$N_{Rd,H1,s}$ [kN] | Timber<br>$N_{Rk,H2,w}$ [kN] | Steel<br>$N_{Rd,H2,s}$ [kN] |               |
| PSL 50    | 50x65                | 40.8                        | 51.7                       | 2.9                          | 2.4                         | 5.6                          | 1.3                         | KAO-L-PSL-01  |
| PSL 70    | 70x70                | 60.5                        | 51.7                       | 2.9                          | 2.4                         | 8.2                          | 1.3                         |               |
| PSL 90    | 90x90                | 77.3                        | 51.7                       | 2.9                          | 2.4                         | 11.2                         | 1.3                         |               |
| PSL 100   | 100x100              | 85.7                        | 51.7                       | 2.9                          | 2.4                         | 11.2                         | 1.3                         |               |
| PSP 70    | 70x70                | 13.4                        | 21.6                       | 11.4                         | 11.2                        | 11.4                         | 11.2                        | KAO-L-PSP-01  |
| PSP 90    | 90x90                | 13.4                        | 21.6                       | 14.6                         | 15.3                        | 14.6                         | 15.3                        |               |
| PSP 100   | 100x100              | 14.1                        | 28.8                       | 16.3                         | 23.2                        | 16.3                         | 23.2                        |               |
| PSP 120   | 120x120              | 14.1                        | 28.8                       | 19.5                         | 28.6                        | 19.5                         | 28.6                        |               |
| PSPO 80   | ø80                  | 13.4                        | 21.6                       | 9.8                          | 25.2                        | 9.8                          | 25.2                        | KAO-L-PSPO-01 |
| PSPO 100  | ø100                 | 13.4                        | 21.6                       | 15.2                         | 30.8                        | 15.2                         | 30.8                        |               |
| PSR 80    | 90x90                | 115.3                       | 49.3                       | -                            | -                           | -                            | -                           | KAO-L-PSR-01  |
| PSR 110   | 120x120              | 235                         | 49.3                       | -                            | -                           | -                            | -                           |               |
| PSRT      | 60x120               | 75.6                        | 57.3                       | 13                           | 0.5                         | -                            | -                           | KAO-L-PSRT-01 |
|           | 70x120               | 88.2                        | 57.3                       | 15.2                         | 0.5                         | -                            | -                           |               |
|           | 80x120               | 100.8                       | 57.3                       | 17.4                         | 0.5                         | -                            | -                           |               |
|           | 90x120               | 113.4                       | 57.3                       | 19.5                         | 0.5                         | -                            | -                           |               |
| PSRU      | 60x120               | 75.6                        | 57.3                       | 13                           | 0.5                         | -                            | -                           | KAO-L-PSRU-01 |
|           | 70x120               | 88.2                        | 57.3                       | 15.2                         | 0.5                         | -                            | -                           |               |
|           | 80x120               | 100.8                       | 57.3                       | 17.4                         | 0.5                         | -                            | -                           |               |
|           | 90x120               | 113.4                       | 57.3                       | 19.5                         | 0.5                         | -                            | -                           |               |

| Connector | Beam dimensions [mm] | Pressure $F_{Ed,V}$         |                            | Shear $F_{Ed,H1}$            |                             | Shear $F_{Ed,H2}$            |                             | Document No.  |
|-----------|----------------------|-----------------------------|----------------------------|------------------------------|-----------------------------|------------------------------|-----------------------------|---------------|
|           |                      | Timber<br>$N_{Rk,V,w}$ [kN] | Steel<br>$N_{Rd,V,s}$ [kN] | Timber<br>$N_{Rk,H1,w}$ [kN] | Steel<br>$N_{Rd,H1,s}$ [kN] | Timber<br>$N_{Rk,H2,w}$ [kN] | Steel<br>$N_{Rd,H2,s}$ [kN] |               |
| PST 70    | 70x80                | 31.9                        | 117.5                      | 2.5                          | 3.7                         | 8.8                          | 7.1                         | KAO-L-PST-01  |
| PST 90    | 90x90                | 31.9                        | 117.5                      | 2.5                          | 3.7                         | 12                           | 7.1                         |               |
| PST 100   | 100x100              | 31.9                        | 117.5                      | 2.5                          | 3.7                         | 13                           | 7.1                         |               |
| PST 120   | 120x120              | 31.9                        | 117.5                      | 2.5                          | 3.7                         | 13                           | 7.1                         |               |
| PST 140   | 140x140              | 31.9                        | 117.5                      | 2.5                          | 3.7                         | 13                           | 7.1                         |               |
| PS 84 L   | 160x100              | 29.3                        | 57.3                       | 5.3                          | 2.2                         | 12.2                         | 1.8                         | KAO-L-PS84-01 |

It is always necessary to put nails in the black marked holes. This is the only one proper pattern because too many or too long nails can weaken the wood, it's quite close to edge (rule is stated below).

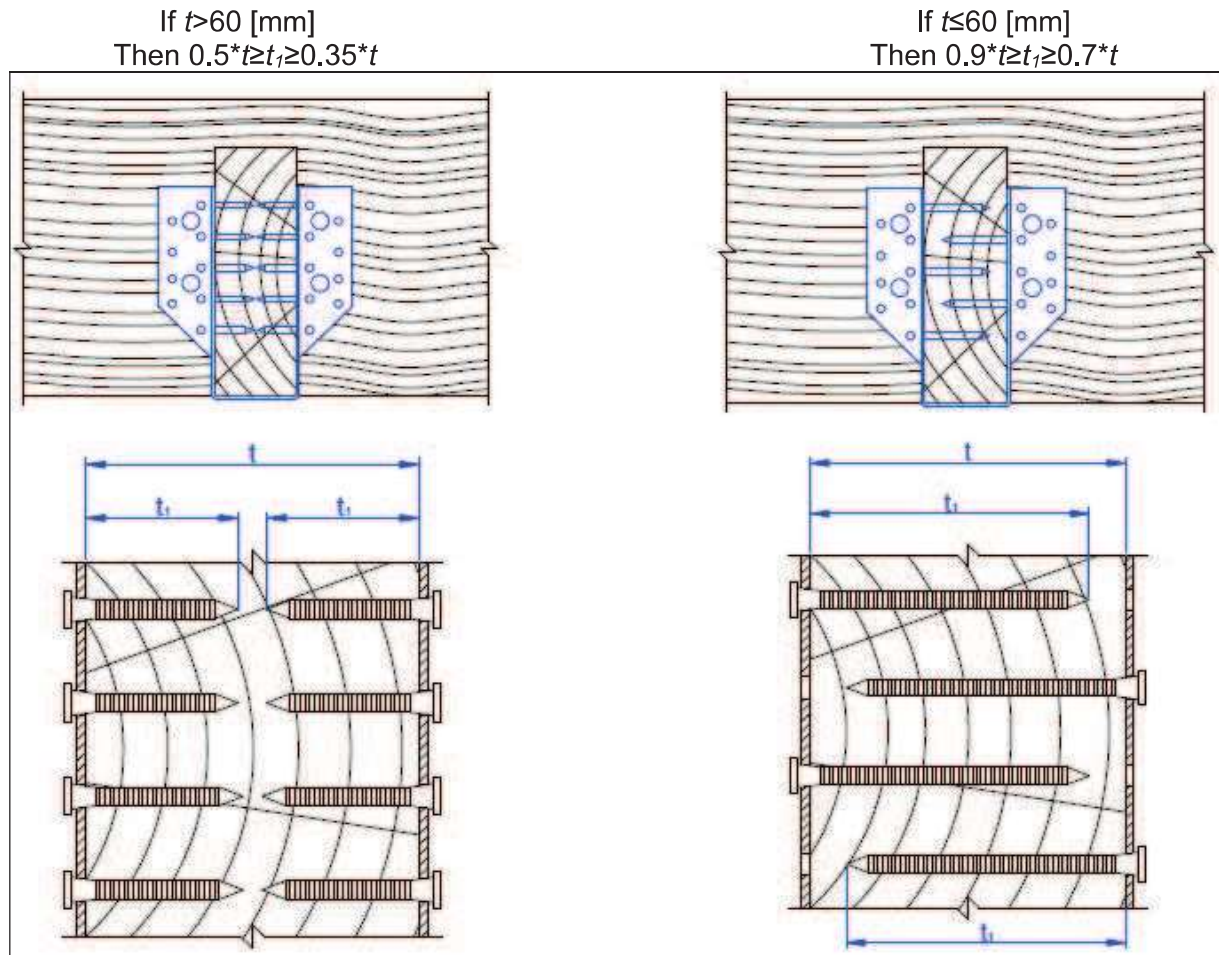
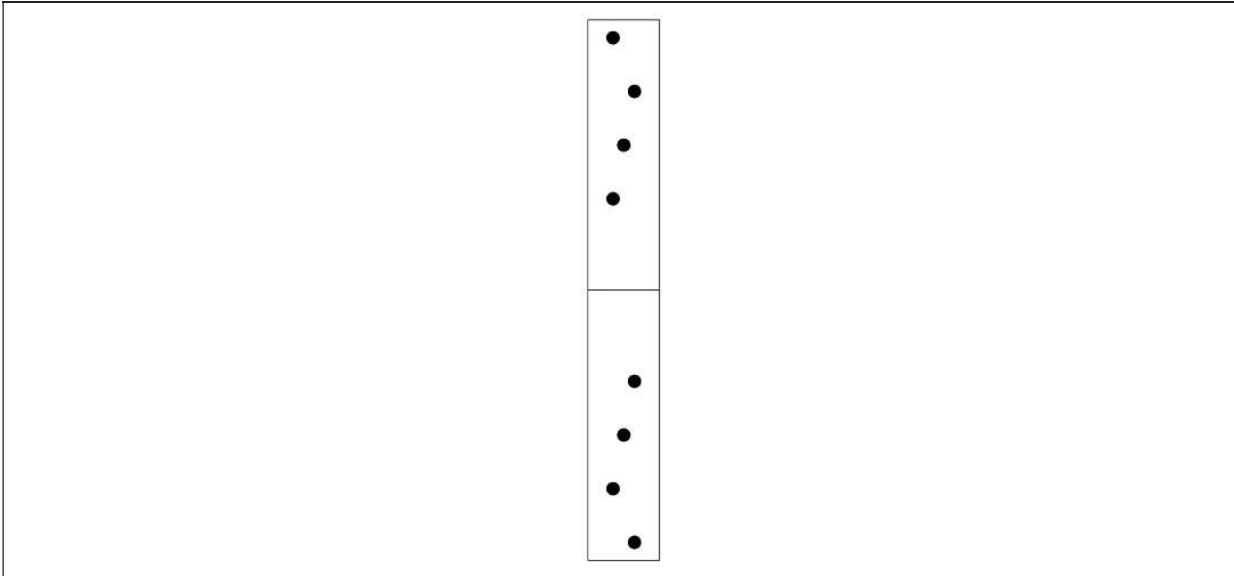
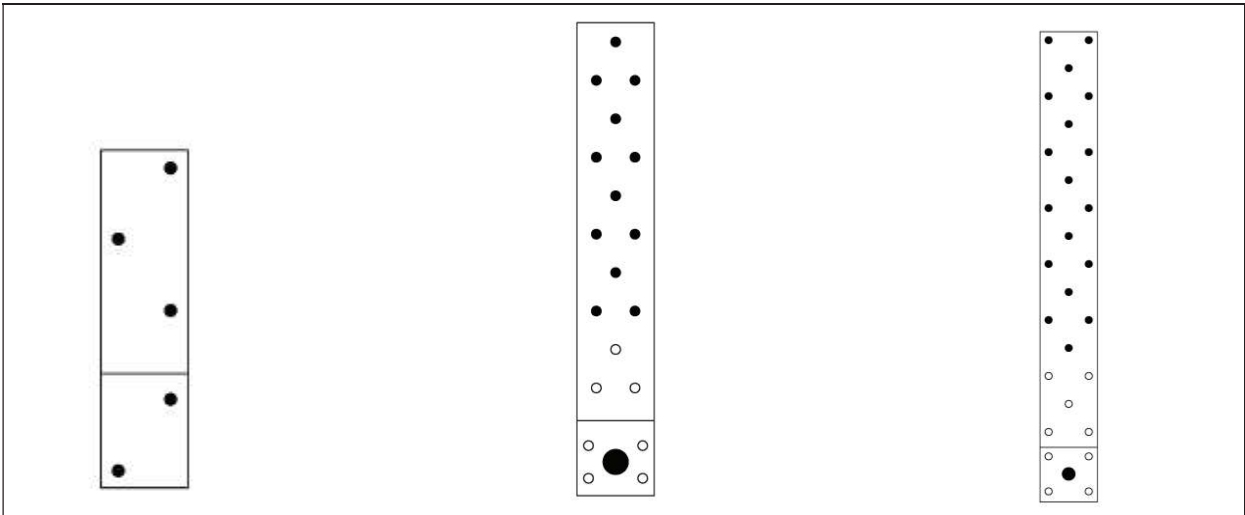

Figure 37 Rule for placement nails



**Figure 38** Type KB 4



**Figure 39** Type KK 0

**Figure 40** Type KK 11

**Figure 41** Type KK 12

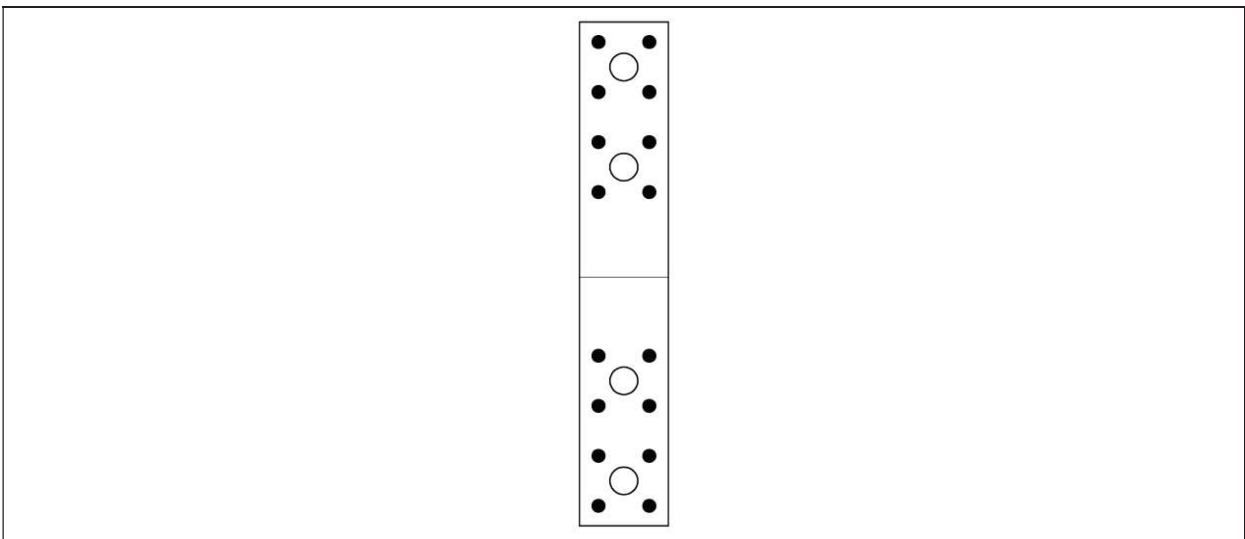

**Figure 42** Type KL 6

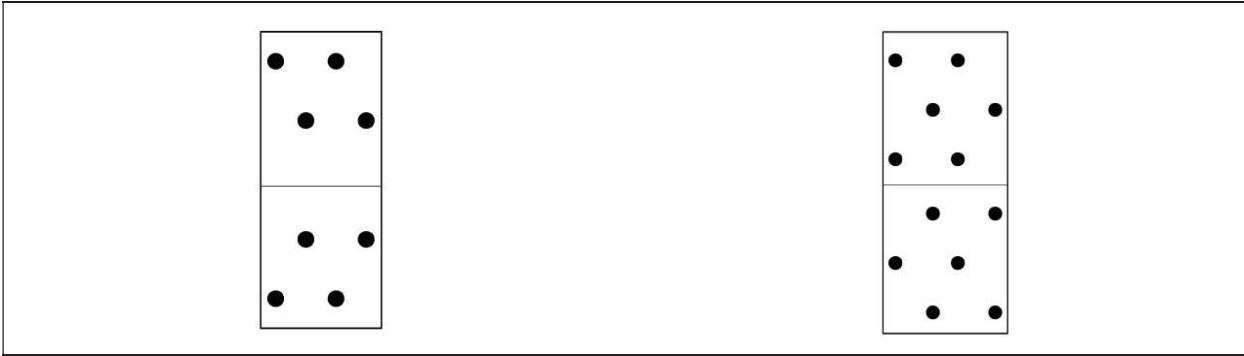

Figure 43 Type KM 17

Figure 44 Type KM 18

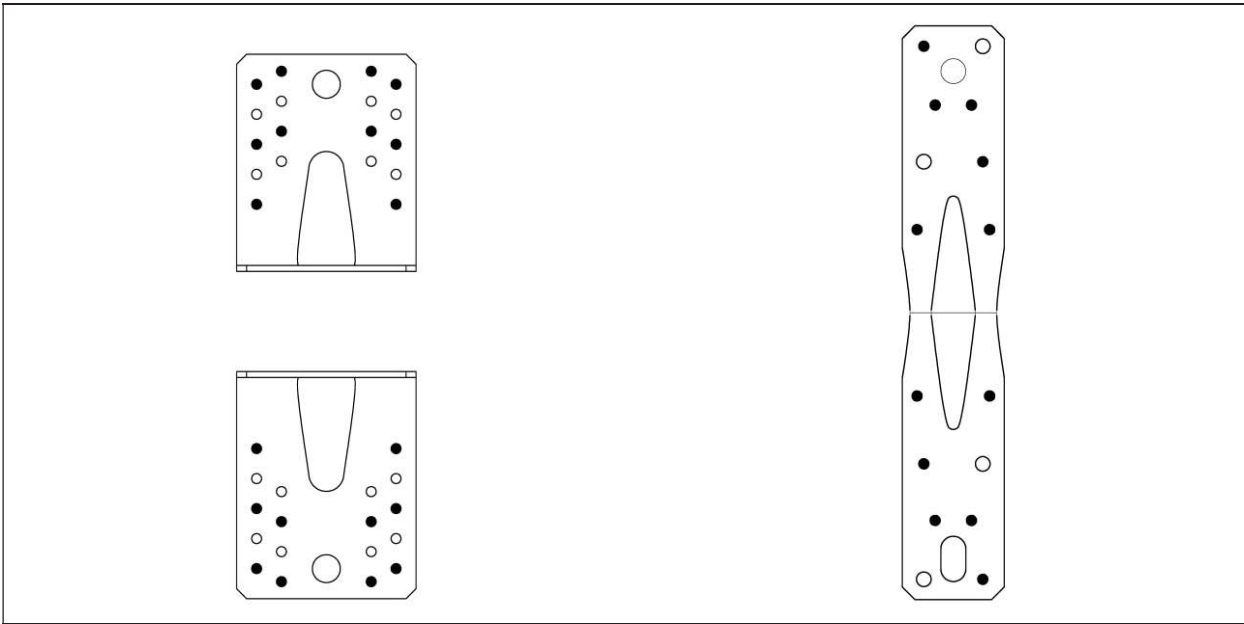

Figure 45 Type KP 2

Figure 46 Type KP 9

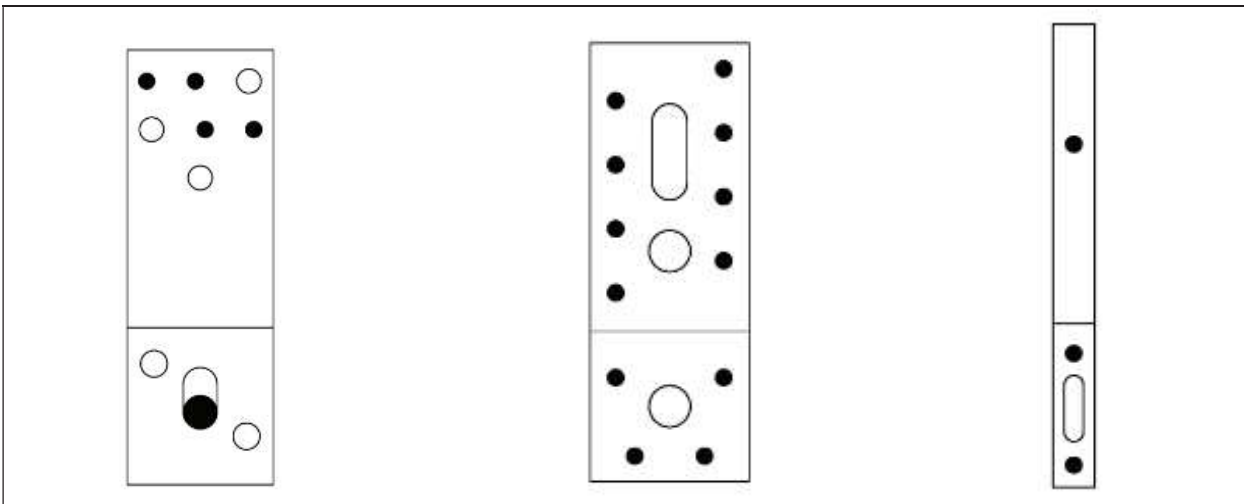

Figure 47 Type KR 4

Figure 48 Type KR 5

Figure 49 Type KR 6

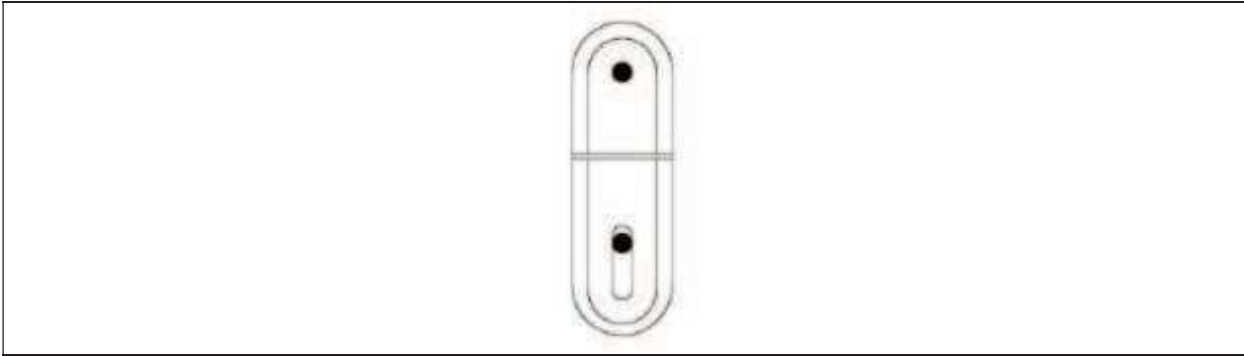

Figure 50 Type KR 7, KRB 7

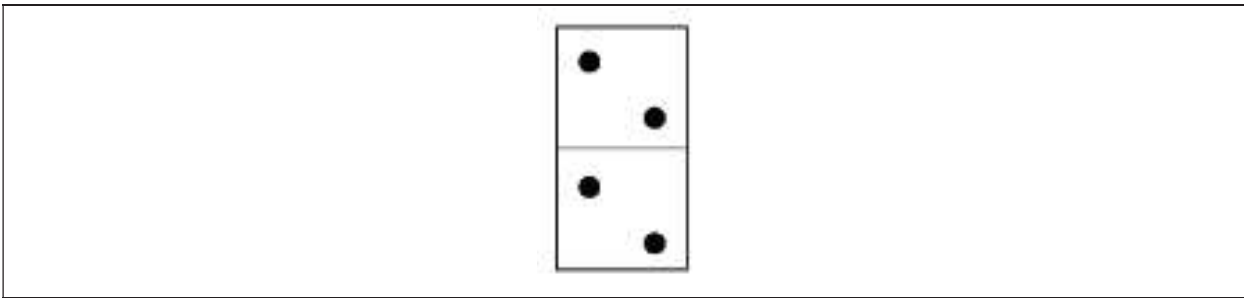

Figure 51 Type KSB 1

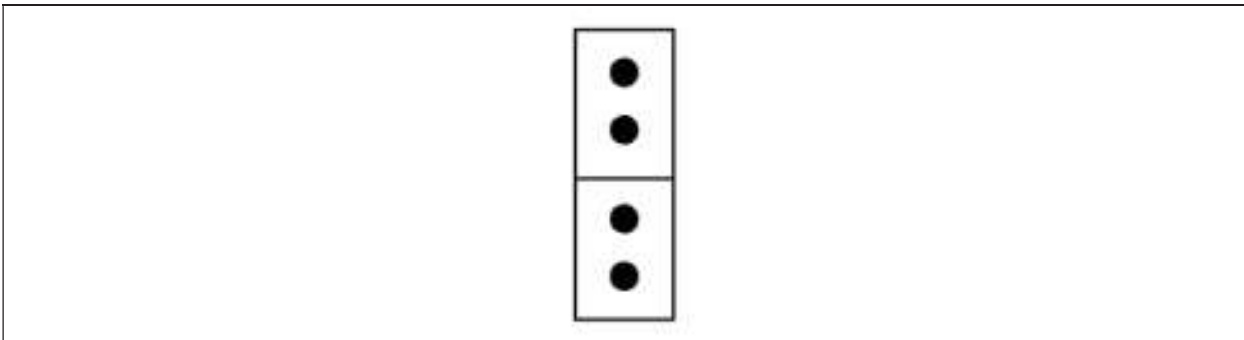

Figure 52 Type KWB 1, KWC 1

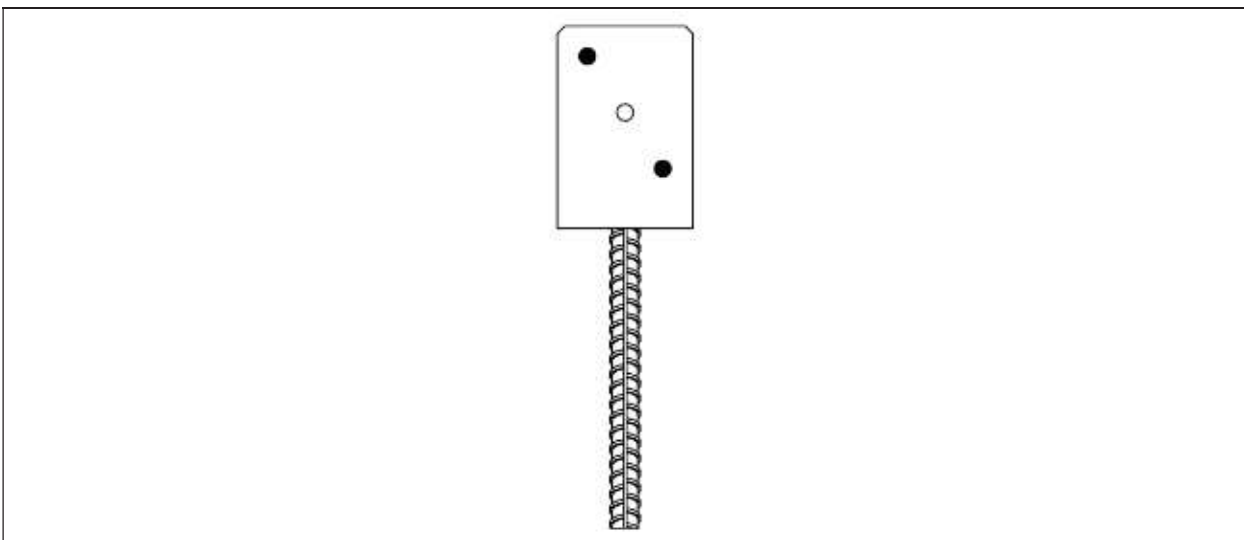
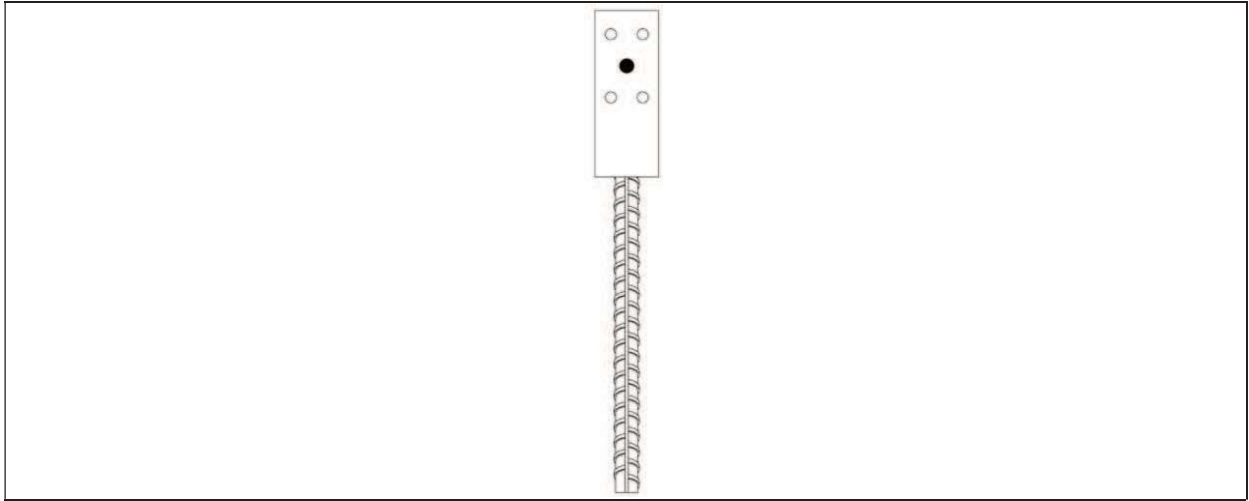
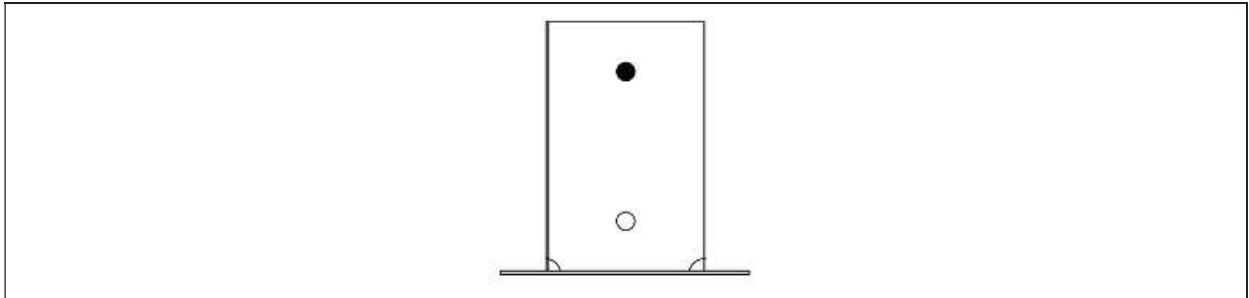

Figure 53 Type PS 84 L



**Figure 54** Type PSL



**Figure 55** Type PSP

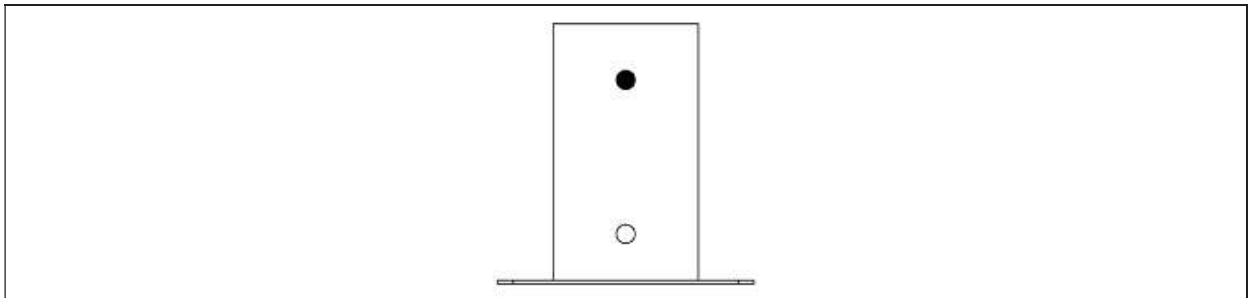

**Figure 56** Type PSPO

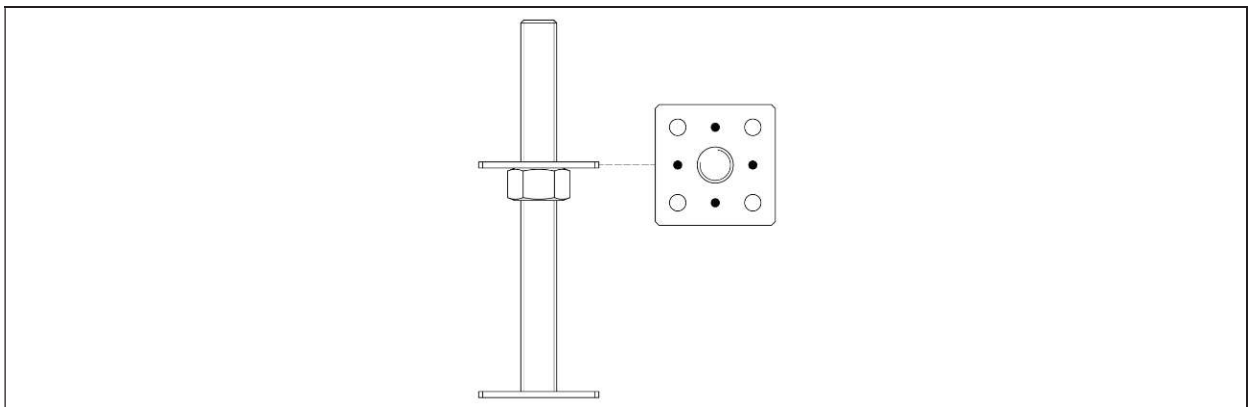

**Figure 57** Type PSR

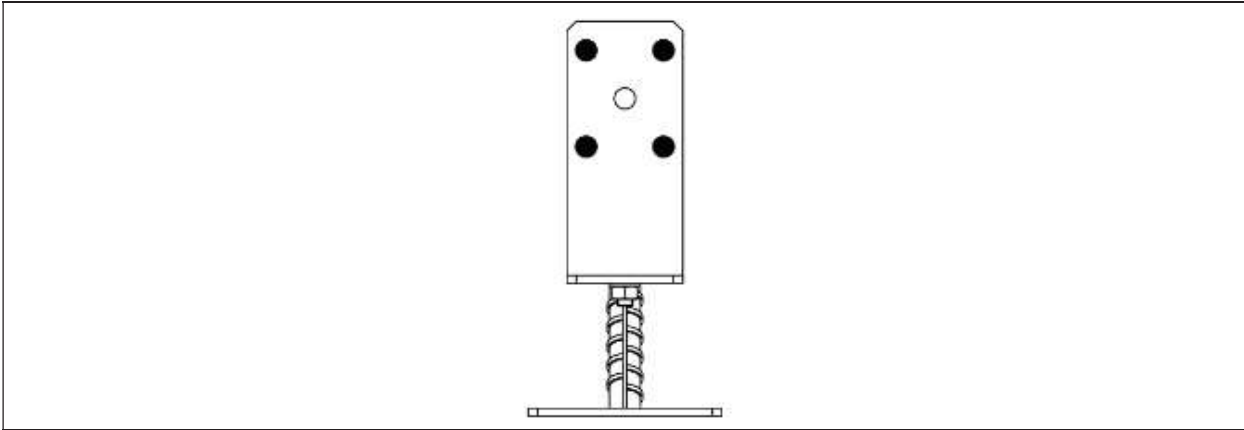

Figure 58 Type PSRT

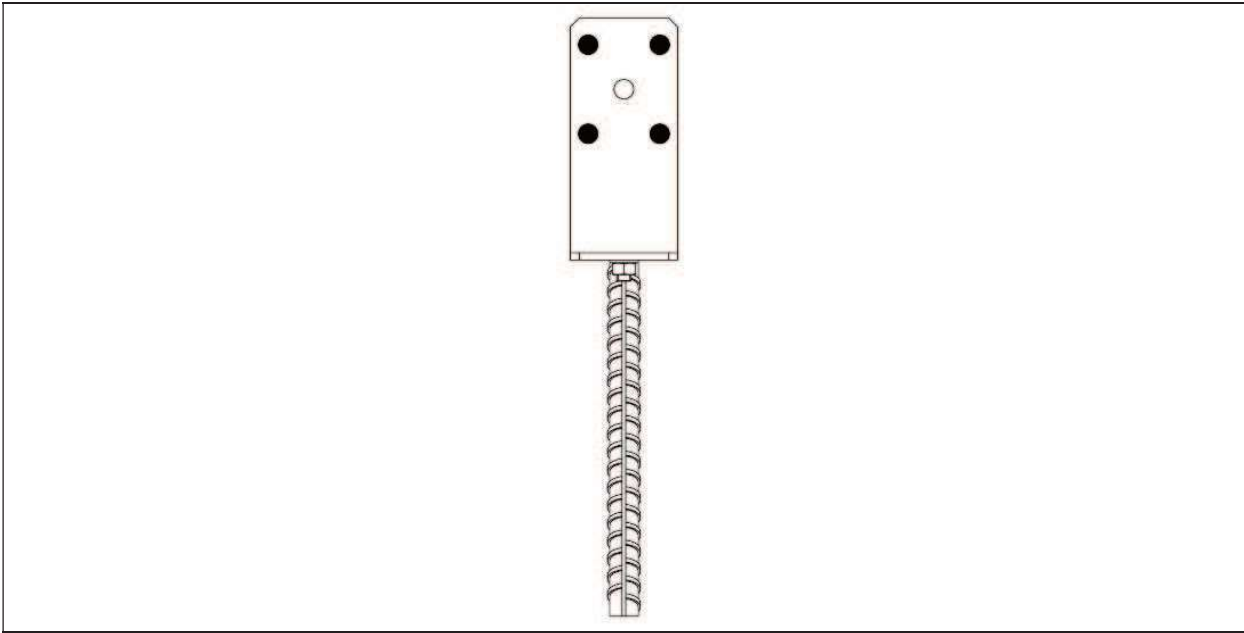

Figure 59 Type PSRU

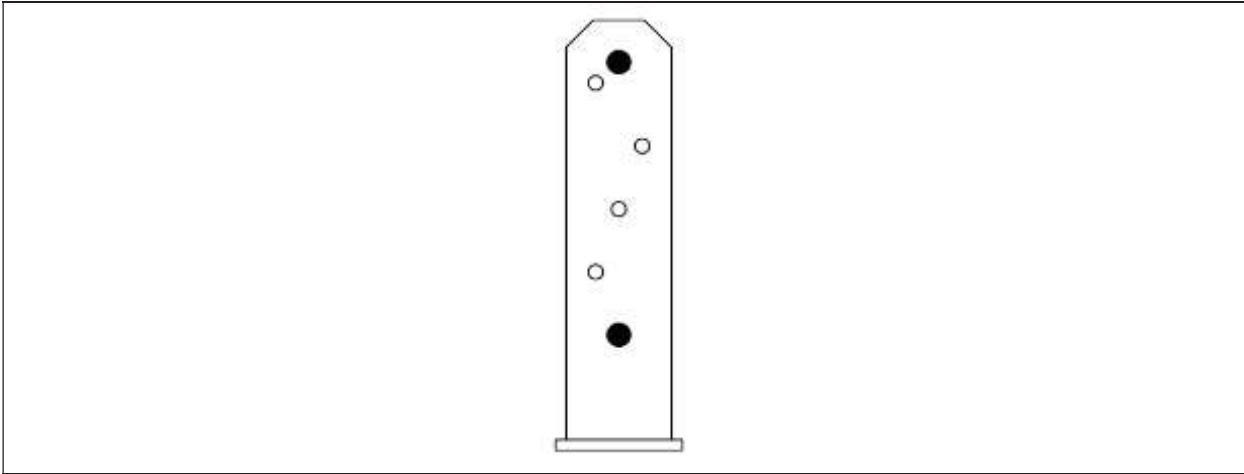

Figure 60 Type PST



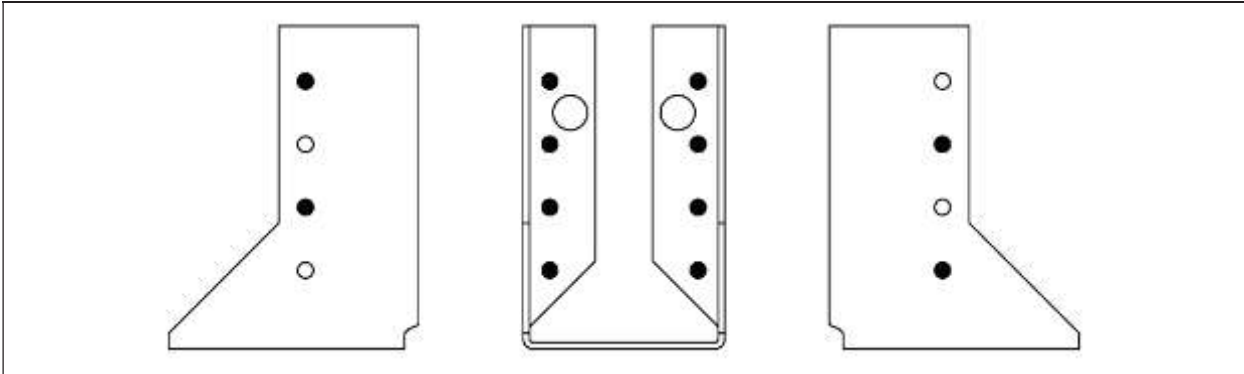

Figure 61 Type WBZ

|   |                    |
|---|--------------------|
| <b>DMX®</b>                                 | <b>ANNEX 5</b>     |
| <b>SPECIFICATION OF CONNECTION ELEMENTS</b> | <b>ETA 15/0725</b> |

**Table 29**

| Connector | Dowel type connectors                                 | Connectors per Detail [pc.] | Connectors per Connection [pc.] |
|-----------|---|-----------------------------|---------------------------------|
| KB 4      | DIN 571 $\varnothing$ 6x35                            | 8                           | 16                              |
| KK 0      | ANCHOR $\varnothing$ 4x50                             | 5                           | 10                              |
| KK 11     | ANCHOR $\varnothing$ 4x50 / ISO 4014 M12x110-5.8      | 12 / 1                      | 24 / 2                          |
| KK 12     | ANCHOR $\varnothing$ 4x50 / ISO 4014 M8x100-5.8       | 18 / 1                      | 36 / 2                          |
| KL 6      | ANCHOR $\varnothing$ 4x50                             | 16                          | 32                              |
| KM 17     | ANCHOR $\varnothing$ 4x50                             | 8                           | 16                              |
| KM 18     | ANCHOR $\varnothing$ 4x50                             | 12                          | 24                              |
| KP 2      | ANCHOR $\varnothing$ 4x50                             | 20                          | 40                              |
| KP 9      | ANCHOR $\varnothing$ 4x50                             | 12                          | 24                              |
| KR 4      | DIN 571 $\varnothing$ 6x35 / ISO 4014 M12x110-5.8     | 4 / 1                       | 8 / 2                           |
| KR 5      | ANCHOR $\varnothing$ 4x50                             | 12                          | 24                              |
| KR 6      | ANCHOR $\varnothing$ 4x50                             | 3                           | 6                               |
| KR 7      | ANCHOR $\varnothing$ 4x50                             | 2                           | 4                               |
| KRB 7     | ANCHOR $\varnothing$ 4x50                             | 2                           | 4                               |
| KSB 1     | ANCHOR $\varnothing$ 4x50                             | 4                           | 8                               |
| KWB 1     | ANCHOR $\varnothing$ 4x50                             | 4                           | 8                               |
| KWC 1     | ANCHOR $\varnothing$ 4x50                             | 4                           | 8                               |
| WBZ 14    | ANCHOR $\varnothing$ 4x50 / ANCHOR $\varnothing$ 4x50 | 8 / 4                       | 8 / 4                           |
| PSL 50    | ISO 4014 M8x70-5.8                                    | 1                           | 1                               |
| PSL 70    | ISO 4014 M8x90-5.8                                    | 1                           | 1                               |
| PSL 90    | ISO 4014 M8x110-5.8                                   | 1                           | 1                               |
| PSL 100   | ISO 4014 M8x120-5.8                                   | 1                           | 1                               |
| PSP 70    | ISO 4014 M10x90-5.8                                   | 1                           | 1                               |
| PSP 90    | ISO 4014 M10x110-5.8                                  | 1                           | 1                               |
| PSP 100   | ISO 4014 M10x120-5.8                                  | 1                           | 1                               |
| PSP 120   | ISO 4014 M10x130-5.8                                  | 1                           | 1                               |
| PSPO 80   | ISO 4014 M10x100-5.8                                  | 1                           | 1                               |
| PSPO 100  | ISO 4014 M10x120-5.8                                  | 1                           | 1                               |
| PSR 80    | ANCHOR $\varnothing$ 4x50                             | 4                           | 4                               |
| PSR 110   | ANCHOR $\varnothing$ 4x50                             | 4                           | 4                               |
| PSRT      | ISO 4014 M10-5.8                                      | 4                           | 4                               |
| PSRU      | ISO 4014 M10-5.8                                      | 4                           | 4                               |
| PST 70    | ISO 4014 M10x90-5.8                                   | 2                           | 2                               |
| PST 90    | ISO 4014 M10x110-5.8                                  | 2                           | 2                               |
| PST 100   | ISO 4014 M10x120-5.8                                  | 2                           | 2                               |
| PST 120   | ISO 4014 M10x140-5.8                                  | 2                           | 2                               |
| PST 140   | ISO 4014 M10x160-5.8                                  | 2                           | 2                               |
| PS 84 L   | ISO 4014 M10x120-5.8 (washer ISO 7094)                | 2                           | 2                               |

|                            |                |
|----------------------------|----------------|
| DMX®                       | <b>ANNEX 6</b> |
| <b>REFERENCE DOCUMENTS</b> | ETA 15/0725    |

- [1] ETAG 015, edition April 2013, *“Three-dimensional nailing plates”* used as European Assessment Document (EAD)
- [2] EOTA TR 016 *“Method of testing Three-Dimensional Nailing Plates, with examples”*
- [3] EN 10346 Continuously hot-dip coated steel flat products - Technical delivery conditions
- [4] EN 10131 Cold rolled uncoated and zinc or zinc-nickel electrolytically coated low carbon and high yield strength steel flat products for cold forming - Tolerances on dimensions and shape
- [5] EN 10025-2 Hot rolled products of structural steels - Part 2: Technical delivery conditions for non-alloy structural steels
- [6] EN 14592+A1 Timber structures - Dowel-type fasteners – Requirements
- [7] EN 1995-1-1 Eurocode 5: Design of timber structures - Part 1-1: General - Common rules and rules for buildings
- [8] EN ISO 12944-2 Paints and varnishes - Corrosion protection of steel structures by protective paint systems - Part 2: Classification of environments
- [9] EN ISO 8970 Timber structures - Testing of joints made with mechanical fasteners - Requirements for wood density
- [10] EN 26891 Timber structures – Joints made with mechanical fasteners – General principles for the determination of strength and deformation characteristics
- [11] EN 384 Structural timber – Determination of characteristic values of mechanical properties and density
- [12] EN 13183-2 Moisture content of a piece of sawn timber - Part 2: Estimation by electrical resistance method
- [13] EN 1309-1 Round and sawn timber - Method of measurement of dimensions - Part 1: Sawn timber
- [14] EN 14358 Timber structures – Calculation and verification of characteristic values
- [15] EN 13501-1+A1 Fire classification of construction products and building elements - Part 1: Classification using test data from reaction to fire tests

#### 4 Assessment and verification of constancy of performance (Hereinafter AVCP) system applied, with reference to its legal base

According to the decision 1997/638/EC<sup>1</sup>, of the European Commission the system(s) of assessment and verification of constancy of performance (see Annex V to Regulation (EU) No 305/2011 and Commission delegated Regulation (EU) No 568/2014) given in the following table applies:

| Product(s)  | Intended use(s)                | Level(s) or class(es) | Attestation of conformity system(s) |
|---|--------------------------------|-----------------------|-------------------------------------|
| Shear plates, toothed-plate connectors, punched nail plates, nailing plates | For structural timber products |                       | 2+                                  |

#### 5 Technical details necessary for the implementation of the AVCP system, as provided for in the applicable EAD

Technical details necessary for the implementation of the AVCP system are laid down in the control plan deposited at Technický a zkušební ústav stavební Praha, s.p.

Issued in Prague on 28.04.2020

By  
Mária Schaan  
Head of the TAB



#### Annexes:

- Annex 1 Product details and definitions
- Annex 2 Loading according to static diagrams  
Calculations according to static diagrams
- Annex 3 The characteristic load-carrying capacities of connectors
- Annex 4 Nailing patterns
- Annex 5 Specification of connection elements
- Annex 6 Reference documents

<sup>1</sup> Official Journal of the European Communities L 268/36 of 19.9.1997